

AT-AUTO & AT-AUTO_{KL}

Operating Manual

Firmware Version 2.11

Multi-Part Owners Manual Consisting of:
Quickstart Guide
Principals of Operation
Firmware Update Guide
Frequently Asked Questions

Palstar, Inc.,
9676 N. Looney Road
P.O. Box 1136
Piqua, Ohio 45356
25 September, 2009

Copyright

PALSTAR, Inc., Piqua, Ohio

2007

Chapter 1

Important Safeguards

WARNING: To reduce the risk of fire or electric shock, do not expose this device to rain or moisture. Do not open the cabinet while operating. Refer servicing to qualified personnel only.

1. Read Instructions-All the safety and operating instructions should be read before the tuner is operated.
2. Retain Instructions-The safety and operating instructions should be retained for future reference.
3. Heed Warnings-All warnings on the tuner and in the instruction manual should be adhered to.
4. Follow Instructions-All operating and use instructions should be followed.

- (a) When the power-supply cord or plug is damaged.
 - (b) If liquid has been spilled, or objects have fallen into the tuner.
 - (c) If the tuner has been exposed to rain or water.
 - (d) If the product does not operate normally by following the operating instructions. Adjust only those controls that are covered by the operating instructions. An improper adjustment may result in damage and will often require extensive work by a qualified technician to restore the tuner to its normal operation.
 - (e) If the tuner has been dropped or the cabinet has been damaged.
 - (f) When the tuner exhibits a distinct change in performance-this indicates a need for service.
15. Antenna Grounding-Before attempting to install this tuner, be sure the antenna and feedline are properly grounded so as to provide protection against voltage surges and built-up static charges.

- (a) Use No.10 AWG copper, No.8 AWG aluminum, No.17 AWG copper-clad steel or bronze wire or larger, as ground wire.
- (b) Secure antenna lead-in and ground wires to house with stand-off insulators spaced from 4 feet to 6 feet apart.
- (c) Mount lightning arrestors and antenna discharge units as close as possible to where the lead-in enters the station.
- (d) A driven rod may be used as the grounding electrode where other types of electrode systems do not exist. Refer to the National Electric Code, ANSI/NFPA 70-1990 for information.
- (e) Use jumper wire not smaller than No.6 AWG copper or equivalent, when a separate antenna grounding electrode is used.

Copyright
PALSTAR, Inc., Piqua, Ohio
2007

Contents

1	Important Safeguards	iii
2	Introduction	2
2.1	General Description	2
2.2	Principal Of Operation	9
2.2.1	Automatic Mode	9
2.2.2	Manual Mode	12
2.2.3	Bypass Mode	13
3	Quickstart Guide	14
3.1	Automatic Mode	15
3.2	Manual Mode	15
3.3	Bypass Mode	16
4	Installation	17
4.1	Unpacking	17
4.2	Location	17
4.3	Electrical Connection and Setup	17
4.3.1	DC Power	18
4.3.2	Vintage Rig Setup	18
4.3.3	Icom Rig Setup	19
4.3.4	Icom Rig With HF Amplifier Setup	21
4.3.5	Kenwood Rig Setup	26
4.3.6	TenTec Omni VII/Jupiter Setup	28
4.3.7	Yaesu Rig Setup	30
5	Detailed Operation	32
5.1	General Description	32
5.2	Automatic Mode	32
5.2.1	Automatic Frequency Following	34
5.2.2	Radio External Tuner Control	34

5.3	Manual Mode	37
5.4	Bypass Mode	40
6	AT-AUTO_{KL} QRO Keyline	43
6.1	Retrofitting to Older AT-AUTOs	43
6.2	Electrical Connection and Setup	43
6.3	Firmware Configuration	45
6.4	Operation	46
7	Firmware Configuration	48
7.1	General Description	48
7.2	Default AT-AUTO Settings	48
7.3	Accessing the Service Menu	49
7.3.1	Setup Auto-Tune	51
7.3.2	Set Startup Mode	52
7.3.3	Setup Icom CI-V	53
7.3.4	Configure RF Output	54
7.3.5	Configure Bypass	54
7.3.6	Configure Radio	55
7.3.7	Configure AT-AUTO Serial Interface	57
7.3.8	Erase Match Memory	60
7.3.9	Adjust A-D Inputs?	60
7.3.10	Display SWR?	60
7.3.11	Configure QRO	60
7.3.12	Tx/Rx Freq Split	60
8	Split-Frequency Operation	61
9	Firmware Update Guide	63
9.1	Hardware Requirements for Firmware Updating	66
10	Rear-Panel Pinouts and Interface Cables	67
10.1	Radio Tuner Handshake	67
10.2	Radio/Computer Serial Data Interface	67
10.3	Radio/Computer Serial Data “Y” Interface	71
11	Remote Control	73
11.1	General Description	73
11.1.1	Example Command Strings	74
11.1.2	Sub-Command Structure and Data Syntax	74

12 Analog Power Meter	78
12.1 Reading Peak Power	78
12.2 Calibration	79
13 Operating Tips	82
13.1 QRO Operation	82
13.2 CI-V Passive Listening	82
13.3 CAT Passive Listening	83
14 Internal Jumper Settings	84
14.1 Reset Enable	84
14.2 CI-V Tx Enable	84
14.3 Jumper Access	85
15 Firmware Revision Summary of Changes	87
15.1 Version 2.00 Bug Corrections	87
15.2 Version 2.00 New Firmware Features	88
15.3 Version 2.01 Bug Corrections	90
15.4 Version 2.01 New Firmware Features	91
15.5 Version 2.02 Bug Corrections	91
15.6 Version 2.03 Bug Corrections	91
15.7 Version 2.04 New Firmware Features	91
15.8 Version 2.05 New Firmware Features	92
15.9 Version 2.06 Bug Corrections	92
15.10 Version 2.07 Bug Corrections	92
15.11 Version 2.07 New Firmware Features	93
15.12 Version 2.08 New Firmware Features	93
15.13 Version 2.09 Bug Corrections	94
15.14 Version 2.10 Changes	94
15.15 Version 2.11 Bug Corrections	94
15.16 Version 2.11 New Firmware Features	95
16 Software License Agreement	96
17 Service and Warranty	97
17.1 Limited Warranty	97
17.2 Repair Policy	97
17.3 Return Policy	98

18 Frequently Asked Questions	99
18.1 Serial Port Related Questions	99
18.1.1 Why is there a serial port on the AT-AUTO?	99
18.1.2 Will the AT-AUTO work with my Collins KWM1 and others without a computer interface?	99
18.1.3 Why does the AT-AUTO have an RS-232 port instead of a USB port?	100
18.2 Memory-Related Questions	100
18.2.1 How can I clear the AT-AUTO memories?	100
18.2.2 What happens when I select “Erase Match Mem?” How do the mem- ories work?	100
18.2.3 Can I manually edit the memory settings?	101
18.2.4 How do I control which memory is recalled and used?	101
18.3 Radio-Interfacing Questions	101
18.3.1 Why doesn’t the AT-AUTO work in Smart and Handshake modes with other radios?	101
18.3.2 Will the AT-AUTO automatically follow frequency changes in the IC- 735?	101
18.3.3 How can I make the AT-AUTO follow a specific Icom radio in a multi- radio setup?	102
18.3.4 Why doesn’t “Fine Tune” work with my Collins S-Line?	102
18.4 General Usage Questions	102
18.4.1 How should I setup the Peak-Hold metering for the AT-AUTO to work automatically?	102
18.4.2 How does the AT-AUTO differ from other automatic tuners available to the amateur radio community?	103
18.4.3 Is this a Ham-Band only tuner? Will this work on the MARS frequencies?	103
18.4.4 Why does the AT-AUTO take up to 30 seconds to tune?	103
18.4.5 Why does the AT-AUTO retune at high power when it found a match at low power?	103
18.4.6 The tuner sometimes retunes after autotuning using the radio’s “Tuner” button. Why?	104
18.4.7 Why is tuning different depending upon whether using coax-fed or balanced-fed antennas?	104
18.5 Firmware-Specific Questions	108
18.5.1 Does the latest version of the firmware only work with the AT-AUTOs that have the QRO Keyline hardware?	108
18.5.2 Where can I get a copy of the firmware source code?	108
18.5.3 Why should I update to the newer AT-AUTO firmware?	109

19 User Notes **110**

19.1 User Notes - Continued 111

19.2 User Notes - Continued 112

19.3 User Notes - Continued 113

List of Figures

2.1	Front Panel View	4
2.2	Top View (Cover Removed)	6
2.3	Rear Panel View	8
2.4	Functional Block Diagram	9
4.1	Vintage Transceiver /Amplifier to AT-AUTO Connection	19
4.2	Icom Transceiver to AT-AUTO Connection	20
4.3	Icom Transceiver with IC-PW1 to AT-AUTO Connection	22
4.4	Icom Transceiver with IC-PW1 to AT-AUTO Connection and QRO Keyline Control	23
4.5	Icom Transceiver with Tokyo Hy-Power HL-1.5KFX to AT-AUTO Connection	25
4.6	Kenwood Transceiver to AT-AUTO Connection	27
4.7	Omni VII Transceiver to AT-AUTO Connection	29
4.8	Yaesu Transceiver to AT-AUTO Connection	31
5.1	Automatic Mode Process	36
5.2	Example Manual Mode Display	37
5.3	Manual Mode Process	39
5.4	Example Bypass Mode Display	40
5.5	Bypass Mode Process	42
6.1	QRO Keyline	44
6.2	QRO Keyline Connections (Other Connections Omitted for Clarity)	45
6.3	Firmware Configuration of QRO Keyline	46
6.4	Automatic Mode with QRO Keyline Enabled	47
7.1	LCD Display - Service Menu Exit Prompt.	49
7.2	Setup: Firmware Options and Flowchart.	50
7.3	Automatic Tuning Menu	51
7.4	Startup Mode Menu.	53
7.5	Setup Icom CI-V Menu.	54

8.1 Transmit/Receive Split Enable (160m) 61

8.2 160m, 1800-1850 kHz Transmit Window Setup 62

8.3 160m, 1872-2000 kHz Transmit Window Setup 62

10.1 Interface Cable Diagrams 70

10.2 Radio/Computer Serial Data “Y” Interface Cable Diagrams 72

12.1 Meter Board Adjustment Locations 81

14.1 Jumper Locations 85

List of Tables

1.1	Specifications	1
2.1	Front Panel Controls as shown in Figure 2.1	5
2.2	Internal Components as shown in Figure 2.2	7
2.3	Rear Panel Components as shown in Figure 2.3	8
5.1	Automatic Mode Control Functions	35
5.2	Manual Mode Control Functions	38
5.3	Bypass Mode Control Functions	41
7.1	Supported SWR Tuning Thresholds	52
7.2	AT-AUTO Compatible CAT/CI-V Radios	55
7.3	Supported Radio Capabilities	56
7.4	Suggested Serial I/O Settings	58
7.5	Serial Data Configuration Options	59
10.1	Rear Panel Connector Descriptions	69
11.1	Remote Control Command Set	75
11.2	AT-AUTO Response to Read Status Command	76
11.3	AT-AUTO Response to Read Power Command	77
14.1	Jumper Settings	86
18.1	Feedline Match Losses	106
18.2	100' Feedline Match Loss for 1.0:1 SWR	106
18.3	100' Feedline Match Loss for various SWR	107

Table 1.1: Specifications

Metering/Display	Dual movement cross-needle with Peak, Peak-Hold, power and frequency compensated coupler, 2X16 LCD alpha-numeric display
Front Panel Controls	
Capacitor	Variable 340pF-14pF-340pF, 5KV Differential
Inductor	26 μ H, 12 ga. wire wound on steatite ceramic core, silver-plated shaft & hardware
Power Range Switch	2-Position, 300/3000 W, manually switched
Real Panel Connectors	
Input Coax	SO239 Teflon connector
Output Coax	SO239 Teflon connector
Balanced Out	Dual high-voltage Nylon66 terminal posts
12 VDC Input	3-Pin Amphenol connector
Aux CIV Ports	Standard 3 mm mono jacks
Transceiver Data Input	5-Pin Amphenol connector
RS-232 Data Input	DB-9 Female
Fuse Holder	5mm X 20mm, 4A 125VAC fast-blo
QRO Keyline Input/Output	2 RCA Phono Jacks (AT-AUTO _{KL} only)
General Specifications	
Frequency Range	1.8-54 MHz
Power Handling	1800 W PEP SSB, 1500 W single-tone continuous
Impedance Range	15 – 1500 Ω , 160 – 6m
Balanced Output	4:1 current balun
Tuning Time	\approx 1 – 30 seconds
Tuning Method	Microprocessor-controlled, stepper motor-driven differential T impedance matching network
Dimensions	12.5" Wide, 6.25" High, 17" Deep (including terminals)
Weight	17 Lbs
Materials	Chassis and top cover are .090 ga. aluminum, gold iridite, Front panel powder coated and epoxy screened

Chapter 2

Introduction

2.1 General Description

Palstar is pleased to bring you the AT-AUTO - An American made, fully-automatic impedance matching network designed to tune antenna systems from 1.8 MHz to 54 MHz. Featuring a robust, precision roller inductor with silver-plated hardware, and a high-voltage differential variable capacitor in a classic T-Match circuit configuration, the AT-AUTO provides a very broad impedance matching range and includes both unbalanced (coaxial) and balanced RF outputs. The AT-AUTO_{KL} includes additional hardware to enable/disable the transmit keying line of an external HF power amplifier, but the AT-AUTO_{KL} is otherwise completely identical to the AT-AUTO. All portions of this manual apply universally to both the AT-AUTO and the AT-AUTO_{KL} except where specifically noted.

Designed to handle a 1500 W continuous carrier, and with no gaps in frequency coverage, the AT-AUTO is well-suited for Amateur Radio, CAP, MARS, Military, and Government HF radio applications. Under microprocessor control, the AT-AUTO continuously monitors forward and reflected power, and when appropriate, automatically adjusts the T-Match circuit for optimum performance without requiring operator intervention.

Although designed for fully automatic operation, the AT-AUTO also enables the user to manually tune or adjust match settings, if desired via the uncluttered front-panel controls. The meter circuitry features Average, Peak, and Peak & Hold display of forward and reflected power, along with SWR. The meter power range (300 W/3000 W) is selected by a front-panel pushbutton.

The AT-AUTO controls are illustrated in Figure 2.1, and are described in Table 2.1 (page 5). An internal view of the AT-AUTO and component descriptions are shown in Figure 2.2 (page 6) and Table 2.2 (page 7), respectively, while the rear panel features are shown and described in Figure 2.3 (page 8) and Table 2.3 (page 8), respectively. A functional block diagram of the AT-AUTO is shown in Figure 2.4 on page 9. AT-AUTO hardware

specifications are shown in Table 1.1 on page 1.

The primary tuner controls are the “Mode”, “Output”, and “Tune-Select” momentary pushbuttons. The “Tune-Select” is also a rotary encoder, used for selection of menu items and control of the inductor and capacitor while in *Manual* or *Bypass* mode. When switched *On*, the AT-AUTO switches to the antenna that had been selected when it was last switched *Off*, and then (default) starts up in the *Automatic* mode. Here the AT-AUTO constantly monitors SWR and will commence tuning when appropriate.

Manual mode is selected by momentarily depressing the “Mode” pushbutton. A subsequent activation of the “Mode” pushbutton selects *Bypass* mode, whereby the RF bypasses the tuning network and is passed directly to either the coaxial or the balanced output. While in *Bypass* mode, momentarily pressing the “Mode” switch again returns the AT-AUTO to *Automatic* mode.

In any operating mode, momentarily depressing the “Output” button enables selection of either the coaxial or the balanced outputs. To change RF output, momentarily depress the “Output” button and then at the prompt, rotate the “Tune-Select” knob until the desired output is displayed, and then momentarily depress the “Tune-Select” knob to select the displayed output (COAX or BAL).

The AT-AUTO firmware is subject to periodic updates. As improvements are made and new features are added, the user may update the AT-AUTO firmware directly from the Palstar website. See page 63 for more detail.

Figure 2.1: Front Panel View

Table 2.1: Front Panel Controls as shown in Figure 2.1

Reference	Control Name or Function
1	Master Power Switch , Controls power to AT-AUTO processor peak-hold meter circuitry, and the meter lamp
2	Power/SWR Meter , Dual-needle meter displays forward and reflected power in Watts. The SWR is displayed on a line beneath the intersection of forward and reflected power needles
3	Main Display , provides AT-AUTO status and user prompts
4	Output , toggles between Coax or Balanced outputs*
5	Tune-Select , Tuning network settings and configuration options*
6	Mode , user selection of operating mode and setup menu access*
7	Lamp , controls power to the Peak and Peak-Hold meter circuitry and illumination of the Power/SWR meter
8	Range , selection of 3000 Watt (in) or 300 W (out) meter scale
9	Peak , displays peak forward power (in) or average forward power (out)
10	Peak-Hold , holds and displays the highest peak forward power (in)

***Note:** Operating mode determines the actual control function. See the respective operating mode descriptions for actual control function and usage.

Figure 2.2: Top View (Cover Removed)

Table 2.2: Internal Components as shown in Figure 2.2

Reference	Description
1	RF input and RF directional coupler
2	RF bypass relay
3	RF output selection relay
4	Unbalanced (Coax) RF output
5	4:1 current balun
6	Balanced RF output
7	340-14-340 pF split-stator capacitor
8	26 μ H roller inductor
9	Stepper motor
10	Master power switch
11	Cross-needle power and SWR meter
12	AT-AUTO processor and display
13	Split-stator capacitor gap detector
14	Roller inductor gap detector
15	Roller inductor travel limit switch

Figure 2.3: Rear Panel View

Table 2.3: Rear Panel Components as shown in Figure 2.3

Reference	Description
1	Balanced RF output
2	Unbalanced (Coax) RF output
3	RF input
4	Auxiliary CI-V jacks
5	Transceiver Data Input. Icom CI-V and external tuner I/O* Kenwood external tuner I/O*
6	RS-232 I/O port. For firmware upgrades and CAT radio interface*
7	5mm X 20mm, 4A 125VAC fast-blow fuse
8	12 VDC input @ \approx 3.5 A peak while tuning
9	QRO Keyline Input/Output (AT-AUTO _{KL} only)

***Note:** Requires specific cable configuration. See Table 10.1 (page 69) for details.

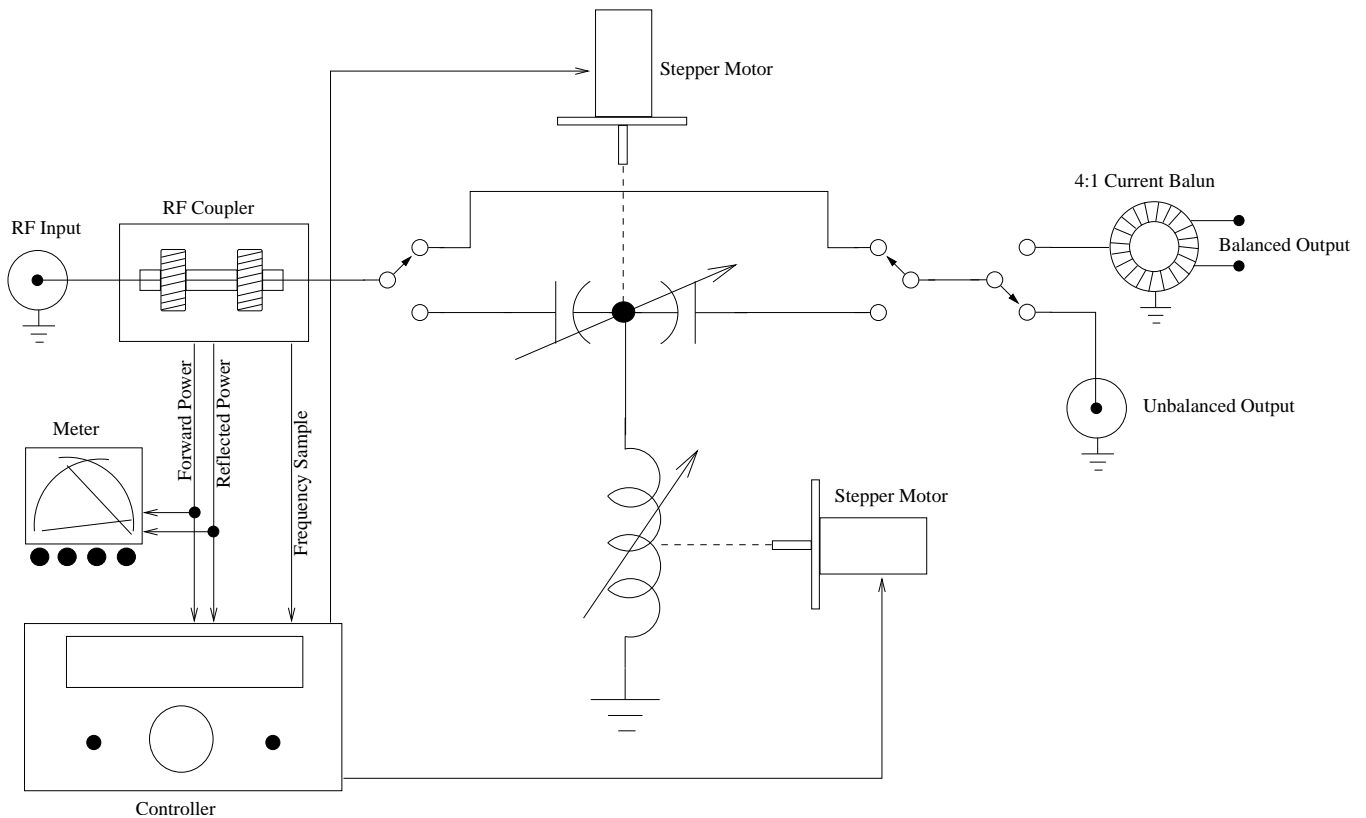

Figure 2.4: Functional Block Diagram

2.2 Principal Of Operation

2.2.1 Automatic Mode

The AT-AUTO is a fully-automatic QRO antenna tuner. It is designed to operate completely without operator intervention, but does provide status and user prompts (if required).

Automatic mode is the default startup mode, but *Manual* mode or *Bypass* mode can be made the default startup mode by appropriate configuration of the AT-AUTO firmware (See Firmware Configuration section, page 48).

While in *Automatic* mode, the tuner continuously samples forward and reflected power. When forward power exceeds a minimum threshold level of approximately 8-10W, the AT-AUTO calculates the corresponding SWR and initiates automatic tuning if required. If the SWR is below the “Tune Start SWR” threshold (default 1.2:1), the AT-AUTO displays the detected good match along with the numerical capacitor and inductor positions, and the selected RF output.

When/if the SWR exceeds the “Tune Start SWR” (default 1.2:1), the AT-AUTO counts

the RF carrier frequency, recalls match settings based upon the carrier frequency and the selected antenna, and then repositions/pre-positions the inductor and capacitor to those recalled settings. There are over 500 such memories in the AT-AUTO for storing antenna, L , and C positions. These memories have been pre-populated with nominal settings at the Palstar facility. Half of these memories are for the balanced output port, and the other half of the memory is for the coaxial output port.

The AT-AUTO uses a roller-inductor for tuning and the initial positioning process may take up to 30 seconds (for example, when repositioning from a setting appropriate for the low-end of the 160m band to something appropriate for the 10m band). During this L and C positioning process, the RF carrier is not required and in order to minimize potential QRM, the AT-AUTO indicates that the carrier is not required by displaying **Prepositioning L & C, Please QRT**.

Once the capacitor and inductor are repositioned within the operating band, the SWR is sampled again. In order to do this, the AT-AUTO requires a steady RF carrier to tune against and therefore prompts the user by displaying **PLS TX 10 W CW**. The AT-AUTO will wait in this state indefinitely until it senses a carrier. If the SWR is still above the "Tune Start SWR" threshold, then tuning will begin by adjusting the capacitor and inductor for minimum SWR.

The tuning process continues until it either times out or an SWR at or below the "Tune Stop SWR" (default 1.05:1) is obtained. If the resulting match is at or below the "Tune Stop SWR", the AT-AUTO displays **Good Match, SWR \leq 1.05:1**. However, if the tuning times out because it was not able to find a match at or below the "Tune Stop SWR", but the resulting match was below the "Tune Start SWR", the AT-AUTO will display **Good Match, SWR \leq 1.2:1. Whenever a successful match is found the precise L and C settings are stored into memory, and the AT-AUTO indicates that it is storing the match settings.**

If the CW carrier is interrupted before tuning is complete, the AT-AUTO will immediately cease tuning and provide an error message indicating that the carrier was lost and that tuning was aborted. The user may also terminate the tuning process by momentarily pressing the "Mode" button.

The automatic tuning is an iterative process which alternates adjustment of the L or C until the SWR is below the "Tune Stop SWR" or until no further improvement in the SWR is made and the tuning process times out (less than 20 seconds).

In order for the tuning process to be successful, as L and C positions are adjusted, the corresponding variations in SWR must be discernable by the AT-AUTO controller circuitry. If the AT-AUTO is profoundly mistuned, such as attempting to tune on 10m while L and C are set for 160m operation, there may be NO discernable variation in SWR as L and C

are manipulated, and automatic tuning will very likely fail. Therefore before commencing automatic tuning, the AT-AUTO always presets the L and C for positions appropriate to the frequency/band of operation.

Note: When recalling the end-users previously stored match settings, it is very likely (indeed expected!) that the subsequent SWR will be very low and subsequent tuning will rarely be required.

Smart Mode

The AT-AUTO is designed to operate in a “Smart” mode with those transceivers so equipped with a CI-V or CAT serial I/O interface. When operating in Smart mode, the AT-AUTO continuously determines the transceiver operating frequency via the serial I/O interface and then recalls L and C match settings from memory and rapidly presets L and C as appropriate. As the transceiver changes from frequency to frequency, or from band to band, the AT-AUTO automatically follows along and presets L and C without the need for the an RF carrier or other operator intervention. This is presently implemented for Icom radios with CI-V interface and for Elecraft (K-2, K-3), Flex Radio (SDR-1000, FLEX-5000), Kenwood (TS-570, TS-2000 etc.), TenTec (Omni VII, Jupiter), and Yaesu (FT-920, FT-990, FT-1000, FT-2000, FT-9000) radios with CAT interfaces.

Handshake Mode

For those radios that provide for control of external tuners, the AT-AUTO is designed to utilize the transceiver’s tuner interface. This is normally via a button on the transceiver labeled, “TUNER.” During *Automatic* mode operation, whenever the radio’s “TUNER” button is depressed, the radio signals the AT-AUTO which is then able to signal the transceiver to produce a CW carrier for tuning. The net effect is that the amount of time that the transceiver is required to produce a carrier for tuning is greatly reduced, thereby minimizing potential for QRM. Here is how it works: When the operator presses the TUNER button on the transceiver, the transceiver signals the AT-AUTO that tuning is requested. The AT-AUTO then signals the transceiver to produce a 10W CW/FM carrier at which time the AT-AUTO samples the SWR and counts the frequency. This process takes approximately $\frac{1}{2}$ second. If the SWR exceeds the “Tune Start SWR” threshold, the AT-AUTO then recalls from memory, the appropriate settings for the Capacitor and Inductor and positions them accordingly.

Once the positioning of L and C are complete, the AT-AUTO again signals the transceiver to produce the 10W CW carrier. If the SWR is still excessive, automatic tuning begins. The moment a good match is found, the AT-AUTO signals the transceiver to cease transmitting and the AT-AUTO automatically stores the match settings.

When using Smart and Handshake modes together, the entire automatic tuning process

is greatly streamlined. As the user returns to previously-matched frequency/antenna combinations, the AT-AUTO precisely recalls and returns to those matched settings, without requiring an RF carrier, and often without requiring subsequent re-tuning.

Currently Handshake mode is implemented for Icom and Kenwood radios only. Support for Yaesu and others may follow thereafter.

Fine Tuning

There will be occasions, when the SWR is well below the “Tune Start SWR” threshold, but the operator may wish to improve the match. This may occur when the operator decides to QSY away from the previously matched frequency, but remain in the same band. Rather than repositioning L and C positions from memory, all that is required is for the AT-AUTO to perform fine adjustments of L and C from their present positions.

Fine Tuning is commanded by momentarily pressing the “Tune-Select” rotary knob, when in *Automatic* mode. If the AT-AUTO has been configured for Handshake mode with the transceiver, the entire fine tune process will complete automatically without further intervention (presently only Icom radios support this feature), and the new match settings will be stored in the AT-AUTO memory.

If Handshake mode is not established, the AT-AUTO will prompt the operator to produce a steady carrier as explained above and the fine tuning process will proceed.

Note: Fine Tune should only be initiated if the AT-AUTO has already performed an automatic tune in the present operating band. When Fine Tune is commanded, the AT-AUTO will use the present L and C positions as the starting point for the fine tuning process. If L and C are at grossly inappropriate positions for the current band of operation, commanding Fine Tune will likely result in inability of the AT-AUTO to find a suitable match.

2.2.2 Manual Mode

The AT-AUTO is also a world-class manual tuner, providing the user with precise manual control of the matching network via the front panel controls and the cross-needle SWR meter. The primary control is the “Tune-Select” knob. Turning this knob will force the microprocessor to move L or C , depending upon which one was selected. Momentarily pressing the “Tune-Select” knob toggles between control of the capacitor or inductor.

The operator manipulates the “Tune-Select” rotary encoder/pushbutton to provide positioning commands to the AT-AUTO microprocessor, which then drives the stepper motors and positions the inductor and capacitor. There is no “heavy lifting” on the part of the operator. The microprocessor monitors the position of the roller inductor and automatically

limits the inductor travel and will prevent the roller inductor wheel from striking the hard stops at the ends of the roller inductor coil.

Handshake Mode

The AT-AUTO is able to signal some Icom and Kenwood transceivers to produce a CW carrier for tuning. When the operator presses the TUNER button on the transceiver, this action is conveyed via the tuner handshaking lines to the AT-AUTO which then controls the transceiver, forcing it to produce a low-power (nominal 10W FM) carrier that the operator may then use to manually tune with.

Once the operator has completed manual tuning, he may then force the transceiver to drop the carrier by either pushing the radio's TUNER button again or by pressing the "Output" knob on the AT-AUTO for approximately 2 seconds. Icom radios may also be commanded to produce a constant carrier by pressing the AT-AUTO's "Output" knob for 2 seconds.

The transceiver TUNER button or the AT-AUTO "Output" button may be used to toggle the steady carrier on or off as needed.

2.2.3 Bypass Mode

Bypass mode is provided for those circumstances when the RF should not be routed through the AT-AUTO's matching network, such as when using a StepIR type of antenna or other resonant antenna systems. *Bypass* mode operation of the AT-AUTO is nearly identical with the *Manual* mode, described previously.

While in *Bypass* mode, the RF matching network may be adjusted via the "Tune-Select" knob, but will have absolutely no effect on the apparent SWR until RF is routed through the AT-AUTO by switching to *Automatic* or *Manual* mode. Handshaking operation is not available when in *Bypass* mode.

The primary control is the "Tune-Select" knob. Turning this knob will force the microprocessor to move L or C , depending upon which one was selected. The operator manipulates the "Tune-Select" rotary encoder/pushbutton to provide positioning commands to the AT-AUTO microprocessor, which then drives the stepper motors and positions the inductor and capacitor. Momentarily pressing the "Tune-Select" knob toggles between control of the capacitor or inductor.

Chapter 3

Quickstart Guide

Note: The AT-AUTO default behavior is to always enter the automatic mode when power is applied. The antenna last selected as well as the positions of the roller inductor and capacitor are automatically stored and subsequently recalled when the AT-AUTO is turned on. The AT-AUTO default behavior is user configurable – See the Firmware Configuration section on page 48 for more details.

In *Automatic* mode, the AT-AUTO autonomously controls when tuning should start and stop, prompting the user if necessary. During *Manual* mode operation, the user controls the tuning network via the “Tune-Select” rotary knob. *Bypass* mode is similar to *Manual* mode except that RF never flows through the RF matching network.

Note! Wait at least 2 seconds after the last movement of the Inductor or Capacitor before removing DC power or turning *Off* the AT-AUTO. The AT-AUTO saves the Inductor and Capacitor positions in non-volatile EEPROM. **If this process is interrupted or otherwise not permitted to complete, synchronization of the inductor and capacitor will be lost and any subsequent automatic tuning attempt will likely fail. If this happens, re-home the inductor and capacitor.** Firmware version 2.01 (and subsequent) will automatically re-home *L* and *C* if the memory write was interrupted.

Note: Always consult your transceiver manufacturer’s instruction manual prior to attempting to interface/operate the radio with the AT-AUTO.

Kenwood Owners: The following information is taken from the Kenwood TS-570S instruction manual.

1. Page 48: “Note: Connect an external antenna tuner to the ANT 1 connector only. After connecting this tuner correctly and selecting ANT 1, the internal tuner will always be bypassed.”
2. Page 61: “Note: While using an external antenna tuner with the TS-570S, you cannot use the 6m band to transmit. Connect your 6 m band antenna to the ANT 2 connector.”

3.1 Automatic Mode

For operation in the *Automatic* mode, please follow these steps:

1. Connect the tuner input to the transceiver with a 50 Ω coaxial cable.
2. Connect the antenna to the tuner output (Coax or Ladder Line).
3. Connect the supplied DC Power Cable to a 12 VDC power source capable of supplying 4 A to the AT-AUTO.
4. Turn *On* the AT-AUTO. The AT-AUTO will display the installed firmware version for 2 seconds and then enter the *Automatic* (default) mode.
5. Select the desired tuner output (balanced/coax) by momentarily pressing the “Output” button, rotate the “Tune-Select” knob until the desired output is displayed. With the desired output displayed, momentarily depress the “Tune-Select” knob.
6. Set the transceiver to the intended operating frequency.
7. Generate a 10-100 W CW/FM carrier on the intended operating frequency.

Note: The AT-AUTO will measure the SWR, and if necessary preset the inductor and capacitor to positions appropriate for the band of operation and then will begin tuning. The presetting operation may take up to 30 seconds when switching from very-low to very-high or from very-high to very-low frequency bands (such as QSYing from 160m to 10m).

8. Follow the prompts on the AT-AUTO display.

Note: When the tuner displays **PLS TX 10 W CW**, you should continuously transmit the FM/CW carrier until tuning is completed. Once tuning is complete, stop transmitting the carrier. **The position of the inductor and capacitor are automatically stored for future retrieval when returning to the same operating frequency.**

3.2 Manual Mode

1. Follow steps 1-7 described above in *Automatic* mode.
2. Select Manual-Mode by momentarily depressing the “Mode” switch.

Note: The display will show *Manual* mode as well as indicate the position of the capacitor, the currently selected antenna, and the position of the inductor in 2nd line of the AT-AUTO display.

3. Generate a 10-100 W CW/FM carrier.
4. Adjust Capacitor and Inductor while observing the SWR on the meter by turning “Tune-Select” knob. The respective C and L positions are shown on the LCD. Switch between Capacitor and Inductor control by momentarily depressing the “Tune-Select” knob.

Note: Wait at least 2 seconds after the last movement of the Inductor or Capacitor before removing DC power or turning *Off* the AT-AUTO. Firmware version 2.01 (and subsequent) will automatically re-home L and C if the memory write was interrupted.

3.3 Bypass Mode

1. Follow steps 1-7 described above in *Automatic* mode.
2. Select Bypass-Mode by repeatedly depressing the “Mode” switch.

Note: The display will show *Bypass* mode as well as indicate the position of the capacitor, the currently selected antenna, and the position of the inductor in 2nd line of the AT-AUTO display.

3. User may adjust Capacitor and Inductor but because RF bypasses the tuning network, repositioning L or C will have **NO** effect on the SWR. The respective C and L positions are shown on the LCD. Switch between Capacitor and Inductor control by momentarily depressing the “Tune-Select” knob.

Note: Wait at least 2 seconds after the last movement of the Inductor or Capacitor before removing DC power or turning *Off* the AT-AUTO. Firmware version 2.01 (and subsequent) will automatically re-home L and C if the memory write was interrupted.

Chapter 4

Installation

4.1 Unpacking

Carefully remove the AT-AUTO from the shipping carton and inspect it for damage. If any damage is apparent, notify the transportation carrier or dealer immediately. **We recommend keeping the packing carton for moving, storing, or reshipping the tuner to us for repair if needed.**

4.2 Location

Select a location for the AT-AUTO that allows the connectors to be free from any possible contact during operation and with unrestricted airflow for cooling.

WARNING: Balanced antennas will produce high RF voltages at the output post connectors. RF burns may result if they are touched during transmission.

WARNING: Do not use more than 1500 Watts average (single tone) through the tuner. Do not use high power with the tuner until it has been tuned at the frequency of operation with a low-power (10-100 Watt) carrier.

4.3 Electrical Connection and Setup

The AT-AUTO should always be connected **between** the antenna system and the station transmitter. For installations that also include an HF amplifier, the AT-AUTO should be connected **between** the HF amplifier and the antenna system.

4.3.1 DC Power

Palstar supplies a DC power cable for use with the AT-AUTO. The DC power supply used should be capable of supplying 4 Amps at 12VDC. The AT-AUTO consumes ≈ 3.5 A whenever the stepper motors are in motion. This is anytime during *Automatic* tuning, or while the user is repositioning *L* or *C* during *Manual* or *Bypass* operation. When the motors are stationary, the AT-AUTO current consumption is ≈ 350 mA.

4.3.2 Vintage Rig Setup

Transceivers lacking the capability to control an external tuner and also lacking CAT/CI-V capability are considered “Vintage” rigs and include such classics the Kenwood TS-830, Drake TR4, everything Collins, and anything Heathkit.

Setup of the AT-AUTO for vintage rig operation is quite simple. Make the electrical connections as shown in Figure 4.1 and then set the radio type to “Vintage Rig” as described in the **Configure Radio** section on page 55.

Note: If using the AT-AUTO_{KL} QRO Keyline, the transmit control line must be routed through the QRO Keyline connectors on the back of the AT-AUTO_{KL}. See AT-AUTO_{KL} QRO Keyline section on page 43 to configure the QRO Keyline.

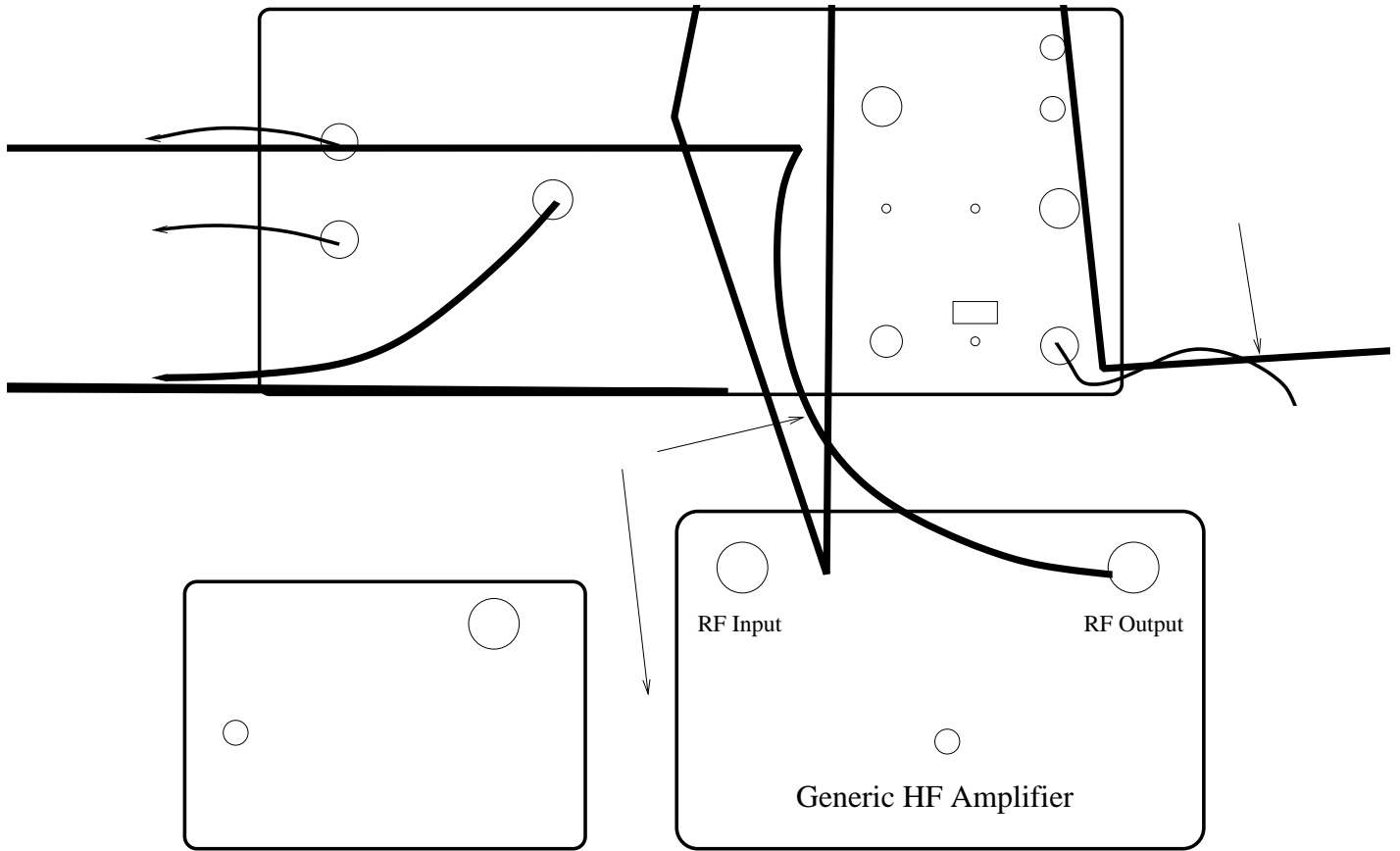

for your specific Icom radio. A typical setup involving an Icom radio is shown in Figure 4.2 the radio's back panel. Please note that if the Icom radio includes multiple antenna connections, that any external tuner connects to the external tuner (the AT-AUTO) via a 4-pin Molex-style connector located on an external tuner via a button on the radio's front panel labeled "TUNER". This interface frequency information from the radio. This interface is often labeled "Remote" on Icom radios. Most newer Icom Figure 4.1: Vintage Transceiver / Amplifier to AT-AUTO Connection 4.3.3 Icom Rig Setup Newer Icom radios incl

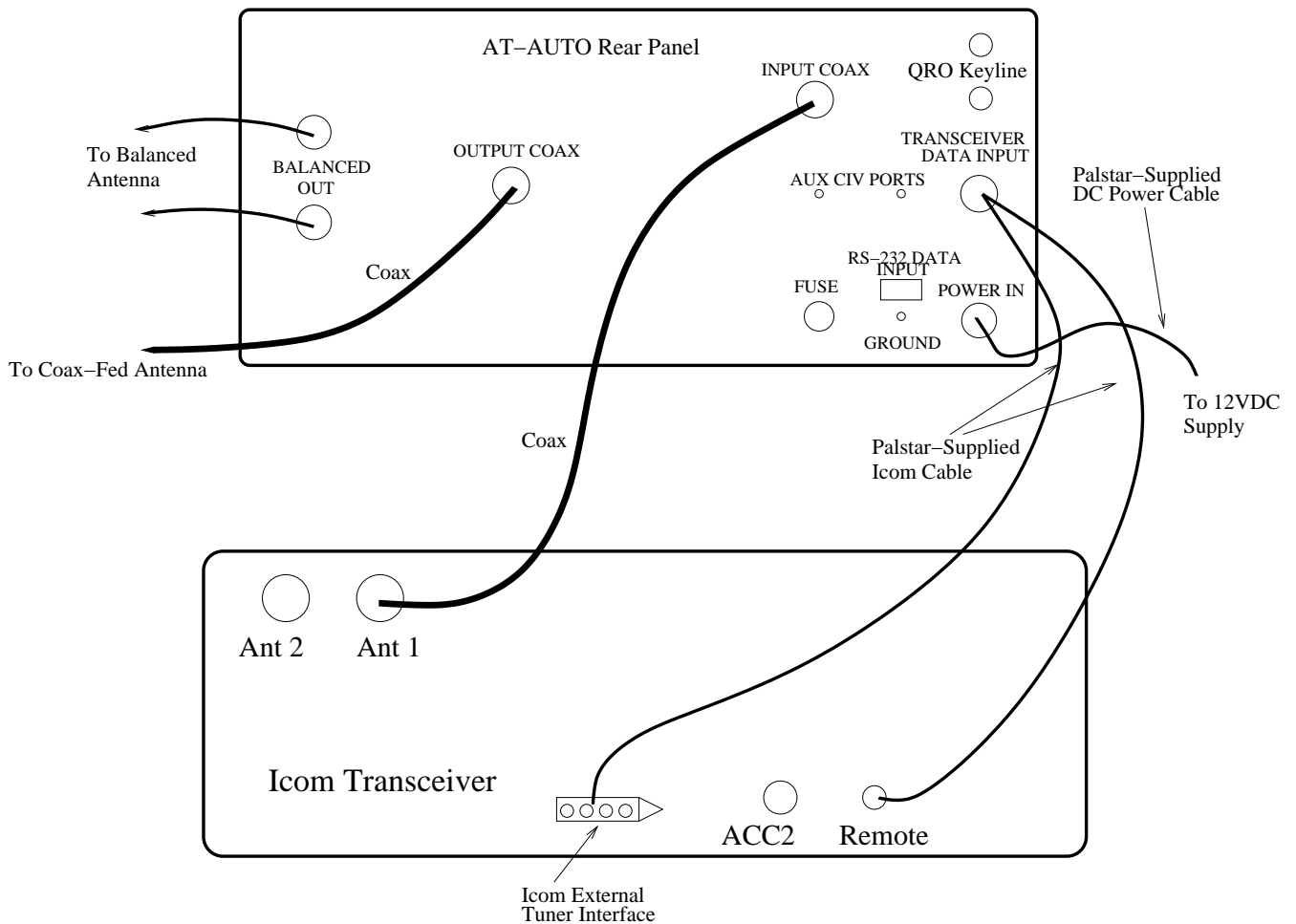

Figure 4.2: Icom Transceiver to AT-AUTO Connection

2. Insert the male 3.5 mm plug into the jack on the back of the Icom radio labeled “Remote”
3. Insert the 4-pin white plastic plug into the corresponding receptacle located on the back of the Icom radio. This plug is often not labeled on the radio, and some radios may not include the 4-pin receptacle (IC-7800 for example)
4. Configure the radio type as described in the **Configure Radio** section on page 55. The radio type should be set to “Icom Normal CI-V & Ext Tuner I/O” or set to “Icom CIV Only No Ext Tuner I/O” if using a radio without external tuner control, such as an IC-7800.
5. Configure the desired CI-V operation as described in the **Setup Icom CI-V** section on page 53
6. Configure the serial I/O baud rate as described in the **Configure AT-AUTO Serial**

Interface section on page 57. Most Icom radios use a default of 9600 baud and the AT-AUTO is also set to 9600 baud by default from the factory

4.3.4 Icom Rig With HF Amplifier Setup

Some amplifiers such as the Icom IC-PW1 and the Tokyo Hy-Power HL-1.5KFX amplifiers are designed to automatically obtain band/frequency information from CAT/CI-V equipped radios. Consult the respective owners manuals for your respective amplifier.

Icom Rig & IC-PW1 with AT-AUTO

Connections for using an Icom radio and Icom IC-PW1 with the AT-AUTO are shown in Figure 4.3. See Figure 4.4 if intending to use the AT-AUTO_{KL} QRO Keyline feature. The IC-PW1 (and the AT-AUTO) will receive frequency information from the CI-V equipped Icom transceiver automatically whenever the radio's frequency changes (via the CI-V bus). The radio should be set to CI-V Transceive mode (see your owner's manual).

Thoroughly read through the Icom IC-PW1 manual as well as the Icom radio manual, particularly the sections regarding CI-V (sometimes referred to as "Remote") operation. Then read through the AT-AUTO manual. The following are suggested steps to setup the AT-AUTO, IC-PW1, and Icom transceiver.

1. Insert the Amphenol plug into the socket to the rear of the AT-AUTO labeled "TRANSCEIVER DATA INPUT", and twist the attachment ring until finger tight
2. Insert the male 3.5 mm plug into the jack on the back of the Icom radio labeled "Remote"
3. Insert the 4-pin white Molex plug into the corresponding receptacle located on the back of the Icom radio. Some radios may not include the 4-pin receptacle (IC-7800 for example)
4. If using the optional QRO Keyline, the Icom-supplied cable must be modified. The transmit control line (ACC1 Pin3) must be routed through the QRO Keyline connectors on the back of the AT-AUTO. See QRO Keyline section on page 43 to configure the QRO Keyline.
5. Set the radio type to either "Icom Normal CI-V & Ext Tuner I/O" or set to "Icom CIV Only No Ext Tuner I/O" as described in the **Configure Radio** section on page 55.
6. Setup the AT-AUTO to "CIV Transceive From Select Icom" and set the radio's CI-V address as described in the **Setup Icom CI-V** section on page 53. The IC-PW1 default CI-V address is 0x55 and the AT-AUTO's default CI-V address is 0xE0, neither of which should require changing.

7. Configure the AT-AUTO serial I/O to 9600 baud as described in the **Configure AT-AUTO Serial Interface** section on page 57. Most Icom radios use a default of 9600 baud and the AT-AUTO is also set to 9600 baud by factory default
8. Set the Icom radio to 9600 baud
9. Set the Icom radio to “CI-V Transceiver” *On*
10. Confirm that the AT-AUTO and IC-PW1 are able to follow frequency changes on the Icom transceiver.

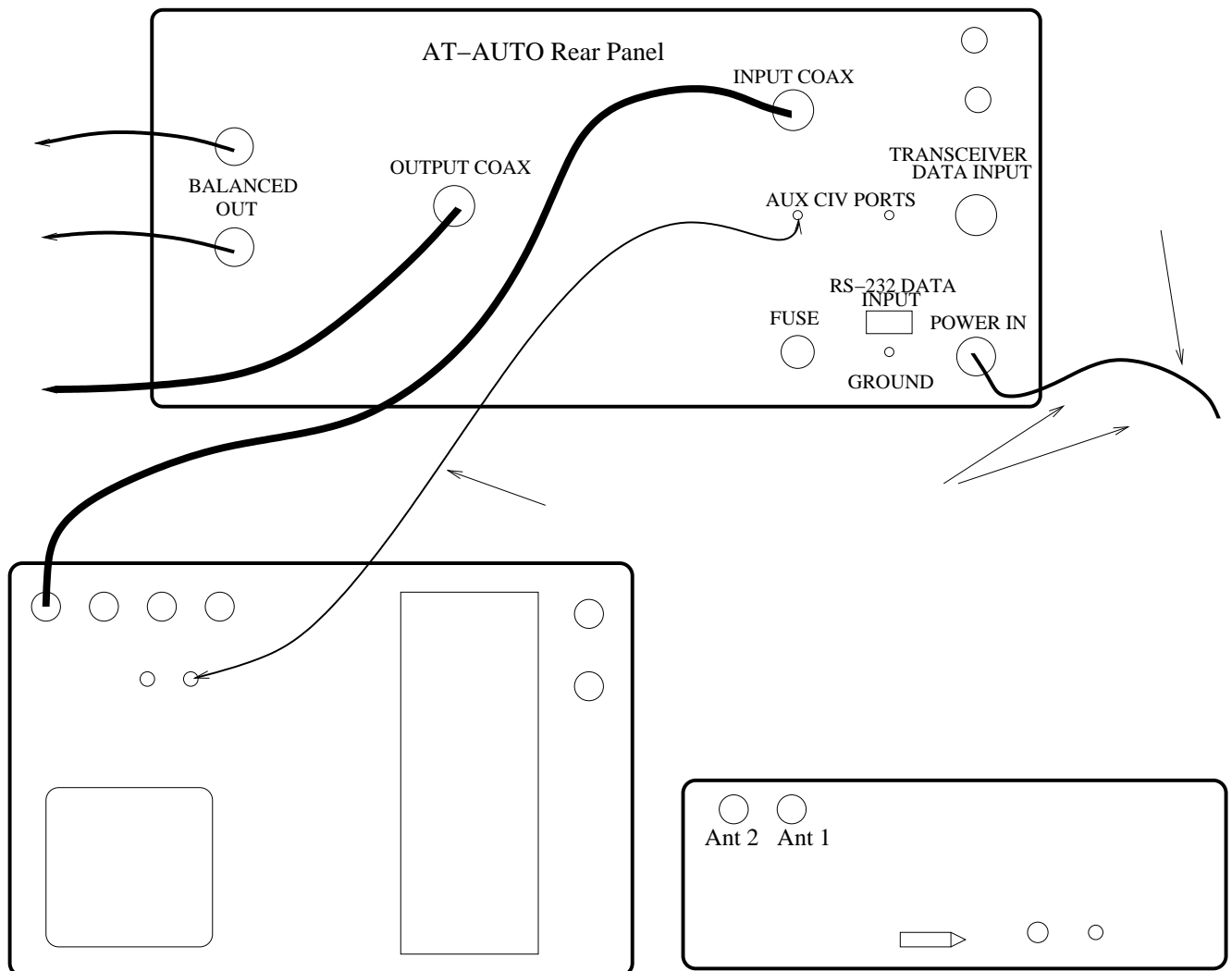

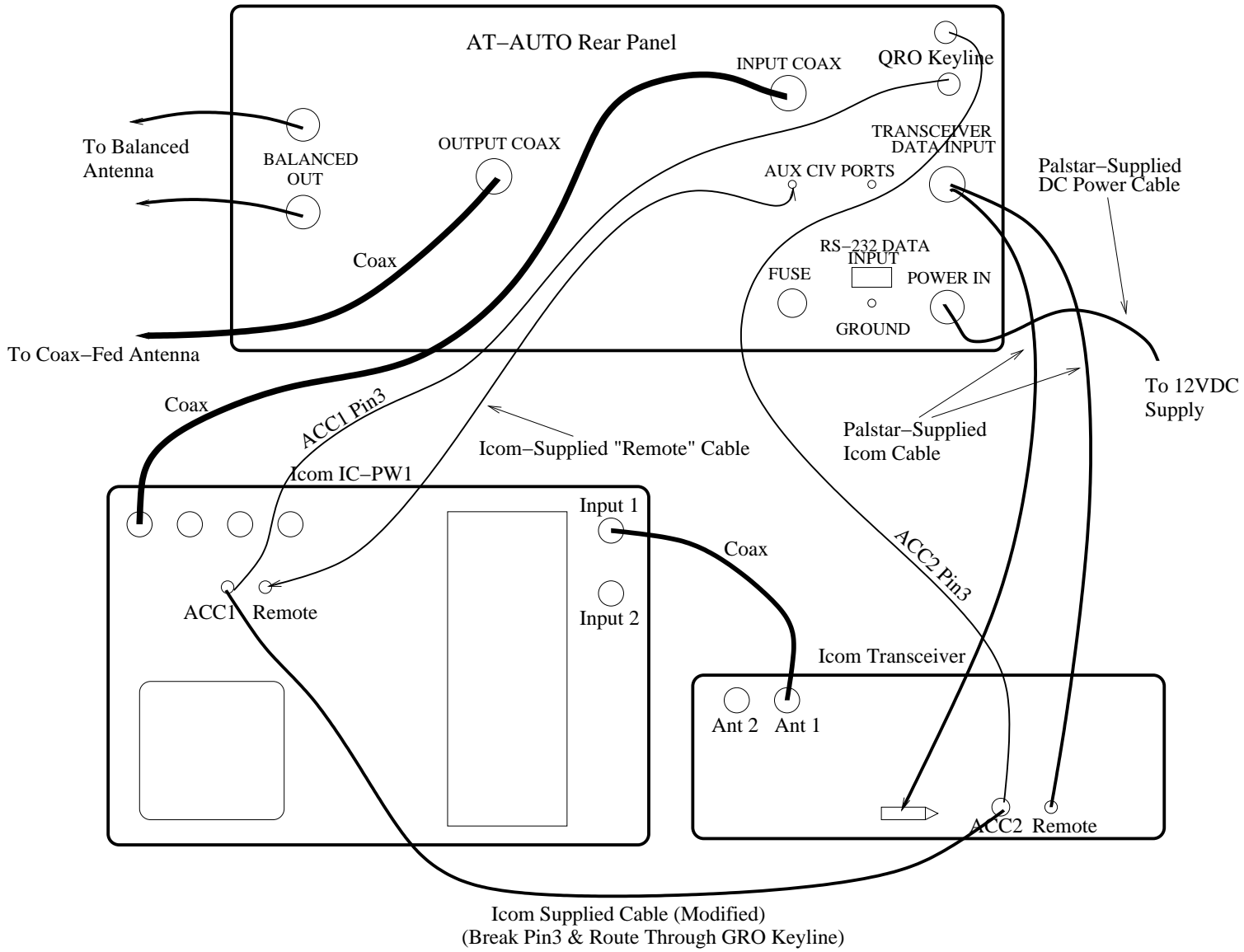

Figure 4.4: Icom Transceiver with IC-PW1 to AT-AUTO Connection and QRO Keyline Control

Icom Rig & Tokyo Hy-Power HL-1.5KFX with AT-AUTO

Connections for using an Icom radio with a Tokyo Hy-Power HL-1.5KFX and an AT-AUTO are shown in Figure 4.5. The HL-1.5KFX (and the AT-AUTO) will receive frequency information from the CI-V equipped Icom transceiver automatically whenever the radio's frequency changes (via the CI-V bus). The radio should be set to CI-V Transceive mode (see your owner's manual).

Thoroughly read through the Tokyo Hy-Power HL-1.5KFX manual as well as the Icom radio manual, particularly the sections regarding CI-V (sometimes referred to as "Remote") operation. Then read through the AT-AUTO manual. The following are suggested steps to setup the AT-AUTO, HL-1.5KFX, and Icom transceiver.

1. Insert the Amphenol plug into the socket to the rear of the AT-AUTO labeled "TRANSCEIVER DATA INPUT", and twist the attachment ring until finger tight
2. Insert the male 3.5 mm plug into the jack on the back of the Icom radio labeled "Remote"
3. Insert the 4-pin white Molex plug into the corresponding receptacle located on the back of the Icom radio. Some radios may not include the 4-pin receptacle (IC-7800 for example)
4. If using the optional QRO Keyline, the transmit control line must be routed through the QRO Keyline connectors on the back of the AT-AUTO. See AT-AUTO_{KL} QRO Keyline section on page 43 to configure the QRO Keyline.
5. Set the radio type to either "Icom Normal CI-V & Ext Tuner I/O" or set to "Icom CIV Only No Ext Tuner I/O" as described in the **Configure Radio** section on page 55.
6. Setup the AT-AUTO to "CIV Transceive From Select Icom" and also set the radio's CI-V address to 0x5C as described in the **Setup Icom CI-V** section on page 53. The default AT-AUTO CI-V address is 0xE0, which should require changing.
7. Configure the AT-AUTO serial I/O to 9600 baud as described in the **Configure AT-AUTO Serial Interface** section on page 57. Most Icom radios use a default of 9600 baud and the AT-AUTO is also set to 9600 baud by default from the factory
8. Set the Icom radio to 9600 baud
9. Consult the radio user's manual and set the Icom radio CI-V address to 0x5C and "CI-V Transceive" to *On* and "CI-V with IC-731" to *Off*
10. Confirm that the AT-AUTO and HL-1.5KFX are able to follow frequency changes on the Icom transceiver

Note! If the HL-1.5KFX is connected to the CI-V bus and the amplifier is turned *Off*, all CI-V communications will fail. Therefore, the HL-1.5KFX must be powered *On* in order for the Icom radio's frequency information to reach the AT-AUTO.

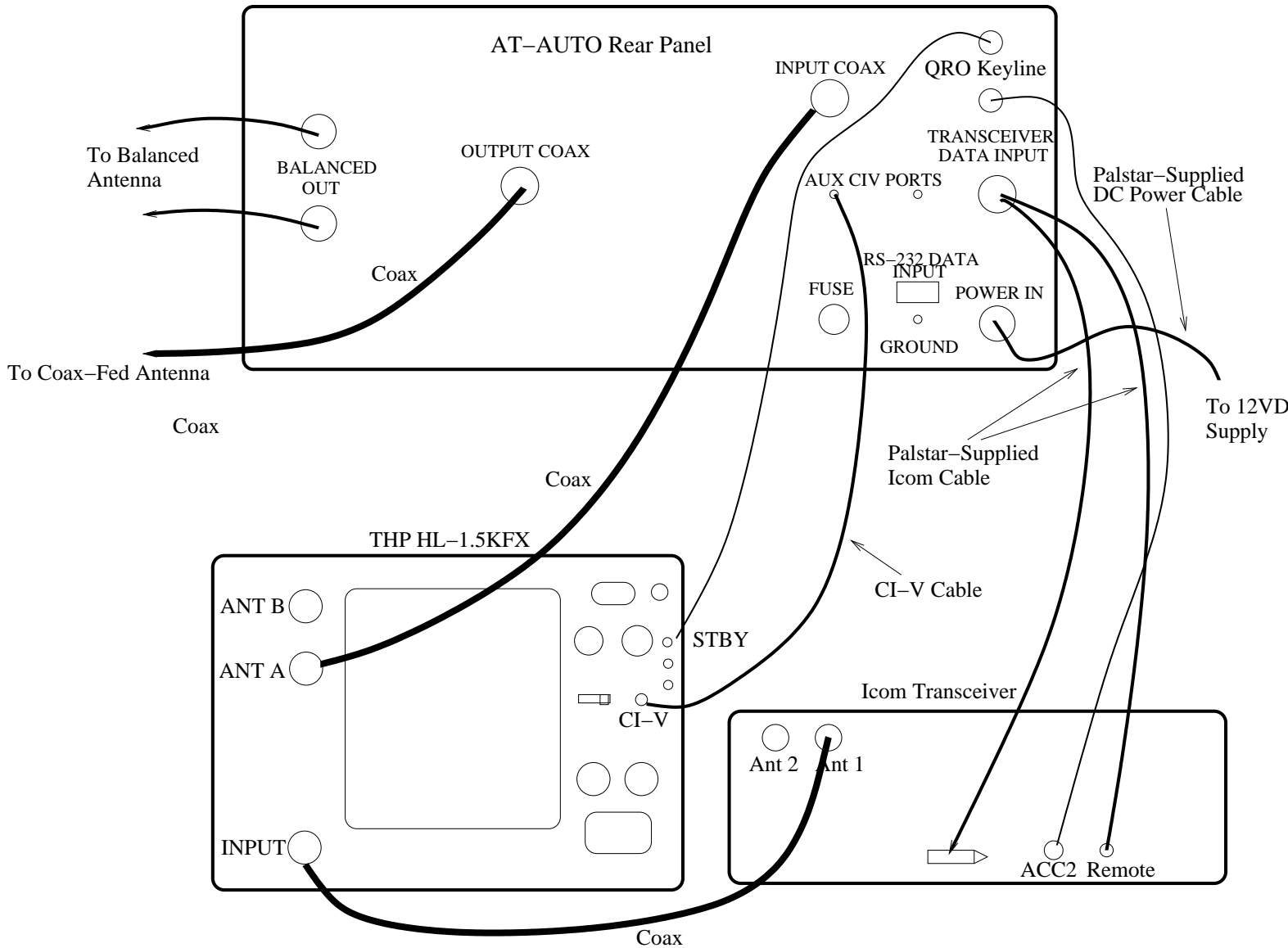

Figure 4.5: Icom Transceiver with Tokyo Hy-Power HL-1.5KFX to AT-AUTO Connection

4.3.5 Kenwood Rig Setup

Recent generation Kenwood radios include a serial interface that the AT-AUTO may utilize to obtain frequency information from the radio. This RS-232 interface is often labeled “COM” on Kenwood radios. Additionally, some newer Kenwood radios also include a provision for controlling an external tuner via a button on the radio’s front panel labeled “TUNER”. This interface connects to the external tuner (the AT-AUTO) via a 6-pin Molex-style connector labeled “AT” which is located on the radio’s back panel.

Please note that if the Kenwood radio includes multiple antenna connections, that any external tuner should be connected to the connector labeled “Ant 1.” Consult owner’s manual for your specific radio. A typical setup involving a Kenwood radio is shown in Figure 4.6.

The following are suggested steps to setup the AT-AUTO to interface with a Kenwood transceiver:

1. Insert the Amphenol plug into the socket on the rear of the AT-AUTO labeled “TRANSCEIVER DATA INPUT”, and twist the attachment ring until finger tight
2. Insert the 6-pin white plastic plug into the corresponding receptacle labeled “AT” located on the back of the Kenwood radio. Some Kenwood radios may not include the “AT” connector
3. Set the radio type to either “Kenwood Normal CAT & Tuner I/O” or set to “Kenwood CAT Only No Ext Tuner I/O” as described in the **Configure Radio** section on page 55
4. Configure the AT-AUTO serial I/O as described in the **Configure AT-AUTO Serial Interface** section on page 57. The AT-AUTO and the Kenwood must both be set to the same baud rate, and the same number of stop bits
5. Confirm that the AT-AUTO is able to follow frequency changes on the Kenwood transceiver

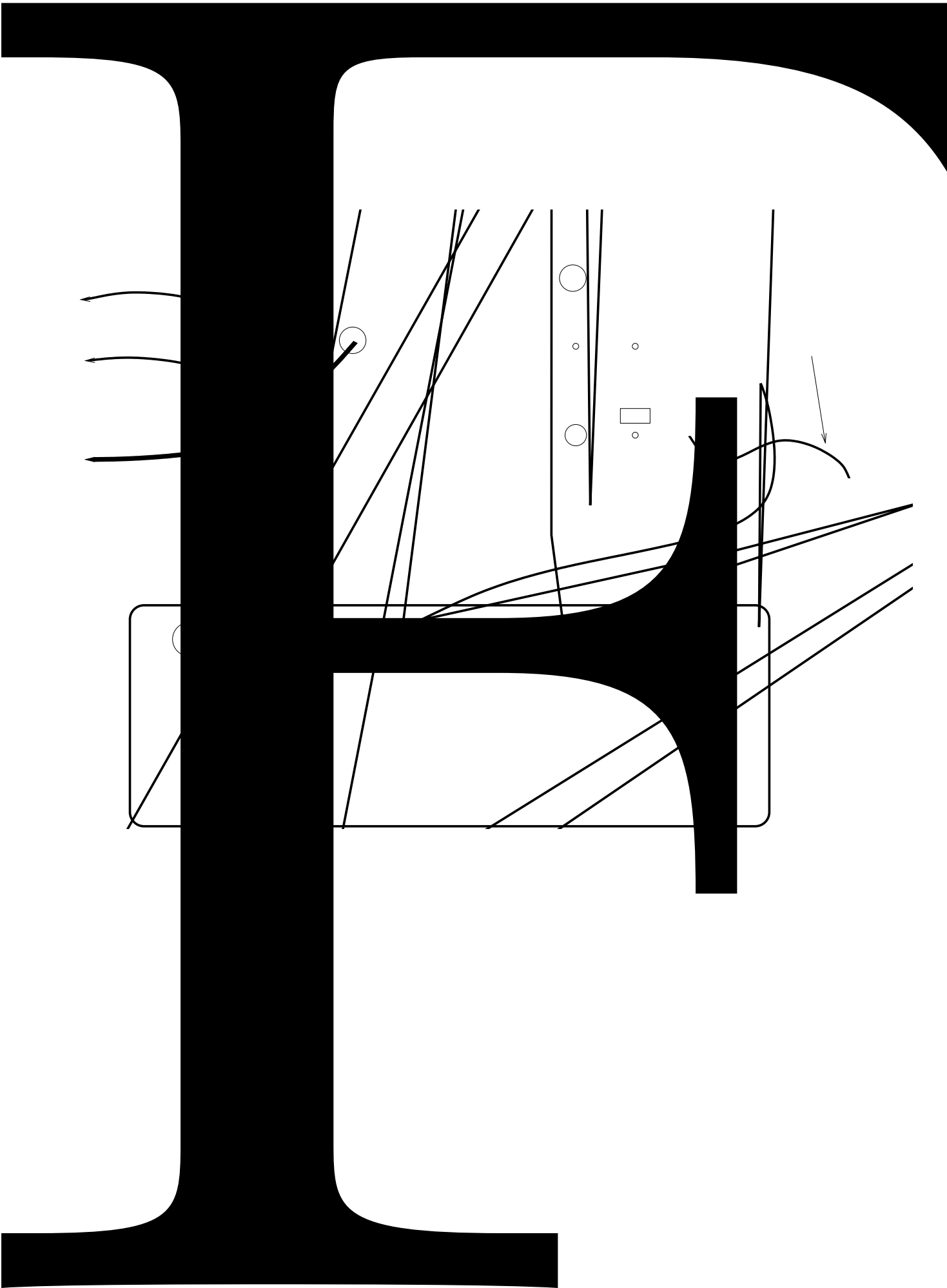

4.3.6 TenTec Omni VII/Jupiter Setup

The AT-AUTO is able to receive frequency information available via the “CAT” (RS-232 interface) when interfaced with either a TenTec “Omni VII” or TenTec “Jupiter” radio. The RS-232 port is labeled “Serial” on the lower rear panel on the Omni VII.

Please note that the Omni VII radio includes multiple antenna connections. We recommend that the AT-AUTO be connected to “ANT 1”. A typical setup involving a Omni VII is shown in Figure 4.7. Jupiter setup will be very similar.

The following are suggested steps to setup the AT-AUTO to interface with a TenTec Omni VII or Jupiter transceiver.

1. Set the radio type to “TenTec Omni VII/Jupiter” as described in the **Configure Radio** section on page 55.
2. Configure the AT-AUTO serial I/O port to 57600 baud, 8 data bits, no parity, 1 stop bit (“57600 8-N-1”) as described in the **Configure AT-AUTO Serial Interface** section on page 57. The TenTec radios are setup for 57600 baud serial data and the AT-AUTO must be set to match the radio’s data rate and number of stop bits.
3. Confirm that the AT-AUTO is able to follow frequency changes on the TenTec transceiver

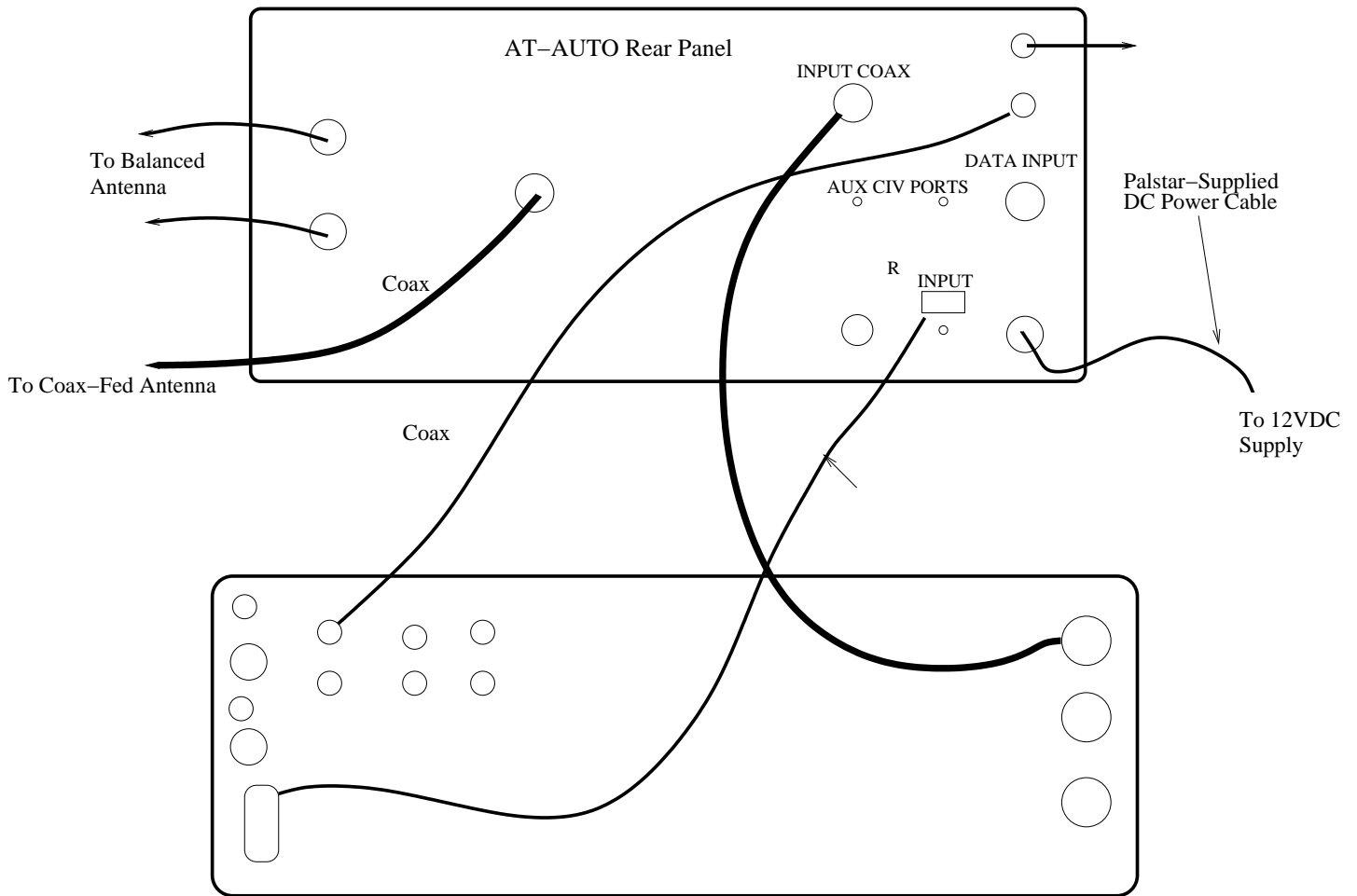

4.3.7 Yaesu Rig Setup

Most Yaesu radios (even older models) include a serial interface that the AT-AUTO may utilize to obtain frequency information from the radio. On most newer generation Yaesu radios, this is generally an RS-232 interface, but some Yaesu radios have serial I/O ports that are TTL and require a level converter to work with the AT-AUTO. This RS-232 interface is often labeled “CAT” on Yaesu radios. Check your radio owner’s manual to determine the specifics of the radio’s serial port.

Please note that if the Yaesu radio includes multiple antenna connections, that any external tuner should be connected to the connector labeled either “Ant 1” or “Ant A.” Consult owner’s manual for your specific radio. A typical setup involving a Yaesu radio outfitted with an RS-232 serial port is shown in Figure 4.8.

The following are suggested steps to setup the AT-AUTO to interface with a Yaesu transceiver.

1. Set the radio type to either “Yaesu FT-2000 No Ext Tuner I/O”, “Yaesu FT-990 No Ext Tuner I/O”, or to “Yaesu FT-1000 No Ext Tuner I/O” as described in the **Configure Radio** section on page 55.
2. Configure the AT-AUTO serial I/O as described in the **Configure AT-AUTO Serial Interface** section on page 57. The AT-AUTO and the Yaesu radio must both be set to the same baud rate. Some Yaesu radios use 2-Stop bits, while others use 1-Stop bit.
3. Confirm that the AT-AUTO is able to follow frequency changes on the Yaesu transceiver

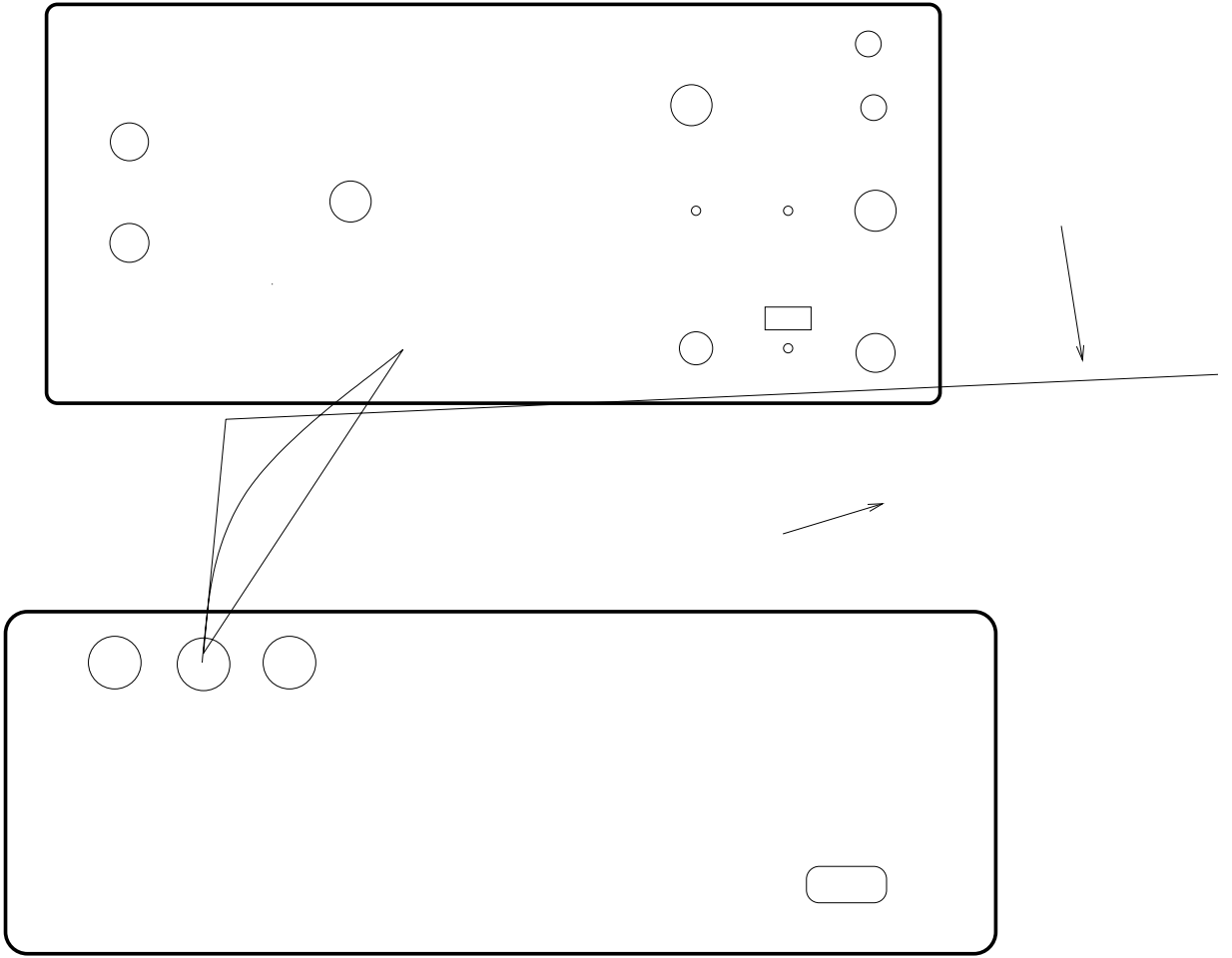

Chapter 5

Detailed Operation

Note: Always consult your transceiver manufacturer’s instruction manual prior to attempting to interface/operate your radio with the AT-AUTO.

Kenwood Owners: The following information is taken from the Kenwood TS-570S instruction manual.

1. Page 48: “Note: Connect an external antenna tuner to the ANT 1 connector only. After connecting this tuner correctly and selecting ANT 1, the internal tuner will always be bypassed.”
2. Page 61: “Note: While using an external antenna tuner with the TS-570S, you cannot use the 6m band to transmit. Connect your 6 m band antenna to the ANT 2 connector.”

5.1 General Description

The AT-AUTO has three primary controls, the “Mode” and “Output” pushbuttons, and the “Tune-Select” rotary encoder/pushbutton, respectively. Depending upon the mode of operation, the action currently taking place, user-selected firmware options, and the type of radio attached/interfaced with the AT-AUTO, these buttons provide various AT-AUTO control features. Generally each button will provide a different function depending upon the length of time that the particular button is depressed. Tables 5.1, 5.2, and 5.3, on pages 35, 38, and 41, lists the control function provided by each of these three controls when operating in *Automatic*, *Manual*, or *Bypass* mode, respectively.

5.2 Automatic Mode

When first turned on, the AT-AUTO momentarily displays the firmware version in the LCD. Approximately two seconds later, the AT-AUTO will enter *Automatic* mode (unless the default firmware configuration was changed) and will begin sampling Forward power.

For normal *Automatic* mode operation, no operator intervention is intended/required other than selection of the intended RF output (Balanced or Coaxial). Merely apply RF power and observe/follow the prompts shown in the Liquid Crystal Display (LCD). The automatic tuning process is shown in flow-chart style in Figure 5.1 on page 36.

The AT-AUTO remembers and automatically selects the RF output that had been in-use when the AT-AUTO was last switched-off. While in *Automatic* Mode, the AT-AUTO continuously monitors Forward power. Whenever approximately 10 W of Forward power has been detected, the AT-AUTO calculates the corresponding SWR and responds appropriately.

If the SWR is determined to be less than the “Tune Start SWR” threshold (default 1.2:1) or better, the AT-AUTO displays “Good Match” on the LCD display as well as the relative *C* and *L* positions and the selected RF output.

Should the SWR exceed the “Tune Start SWR” threshold (default 1.2:1), the AT-AUTO will attempt to improve that match to the “Tune Stop SWR” threshold (default 1.05:1) or better. First, the AT-AUTO counts the RF frequency and then recalls the *L* and *C* match settings. It then automatically repositions *L* and *C* to the recalled match settings and indicates to the user that this is taking place. If the recalled *L* setting is far removed from its present setting, the AT-AUTO will prompt the user to temporarily drop the carrier.

Once the inductor and capacitor have been repositioned, the AT-AUTO prompts the user to provide a steady carrier and will wait indefinitely until either a carrier is applied or the user aborts the automatic tuning. The user should apply a steady 10 W minimum carrier (FM or CW). SSB or modulated AM are NOT appropriate.

If the recalled *L* and *C* settings were for a previously derived match, it is indeed very likely that the preset *L* and *C* settings will provide a good match and the SWR will be less than the “Tune Start” threshold (default 1.2:1) and no tuning will be required. However, if the resultant SWR exceeds the 1.2:1 threshold, the AT-AUTO will commence automatic tuning. While automatic tuning is proceeding, the AT-AUTO displays the changing *C* and *L* positions and indicates that automatic tuning is taking place. Upon finding a good match, the AT-AUTO displays the matched SWR and immediately stores the match settings in non-volatile memory.

Note! Wait until the AT-AUTO has finished saving the new match settings and the LCD is again displaying “Automatic Mode” before removing DC power or turning *Off* the AT-AUTO. The new match settings are permanently stored by overwriting sections of the AT-AUTO firmware. **If this process is interrupted or otherwise not permitted to complete, the firmware may become corrupted, requiring reloading the firmware and/or completely reprogramming the microprocessor at the Palstar facilities.**

5.2.1 Automatic Frequency Following

When interfaced with a CI-V or CAT-supported radio, the AT-AUTO will also automatically follow the radio's frequency changes by immediately recalling the corresponding match settings and presetting the inductor and capacitor accordingly.

5.2.2 Radio External Tuner Control

When interfaced with a radio that also provides control of an external tuner such as an Icom AH-4, or Kenwood AT-300, the radio's external tuner control circuitry provides hardware handshaking between the radio and the AT-AUTO. The user may then momentarily press the radio's **TUNER** button to initiate automatic tuning. The AT-AUTO causes the radio to generate a low-level RF carrier (typically 10 W FM). Once the AT-AUTO senses the RF carrier, it calculates SWR and follows the automatic tuning process previously described. Once the RF carrier is no longer required, the AT-AUTO causes the radio to drop the RF carrier.

When interfaced with an Icom radio with external tuner I/O control, the AT-AUTO is likewise capable of controlling RF carrier generation whenever "fine tune" is commanded.

Table 5.1: Automatic Mode Control Functions

“Mode” Pushbutton	
Short Duration Press	If Tuning In Progress: Aborts automatic tuning attempt If Tuner Idle: Selects <i>Manual</i> mode
Medium Duration Press	No effect
Long Duration Press	Selects AT-AUTO “Configuration Menu”
“Tune-Select” Knob	
Short Duration Press	If Tuner Idle: Commands “Fine Tune” If Prompted: Give user consent to attempt automatic tuning
Medium Duration Press	No effect
Long Duration Press	No effect
Turn CW or CCW	No Effect
“Output” Pushbutton	
Short Duration Press	If band was “auto-bypassed”: Routes RF through AT-AUTO If not “auto-bypassed”: Toggles output to COAX/Balanced
Medium Duration Press	No effect
Long Duration Press	No effect
“Duration” Definition	
Short	\leq 1 second
Medium	2-3 Seconds
Long	\geq 10 seconds

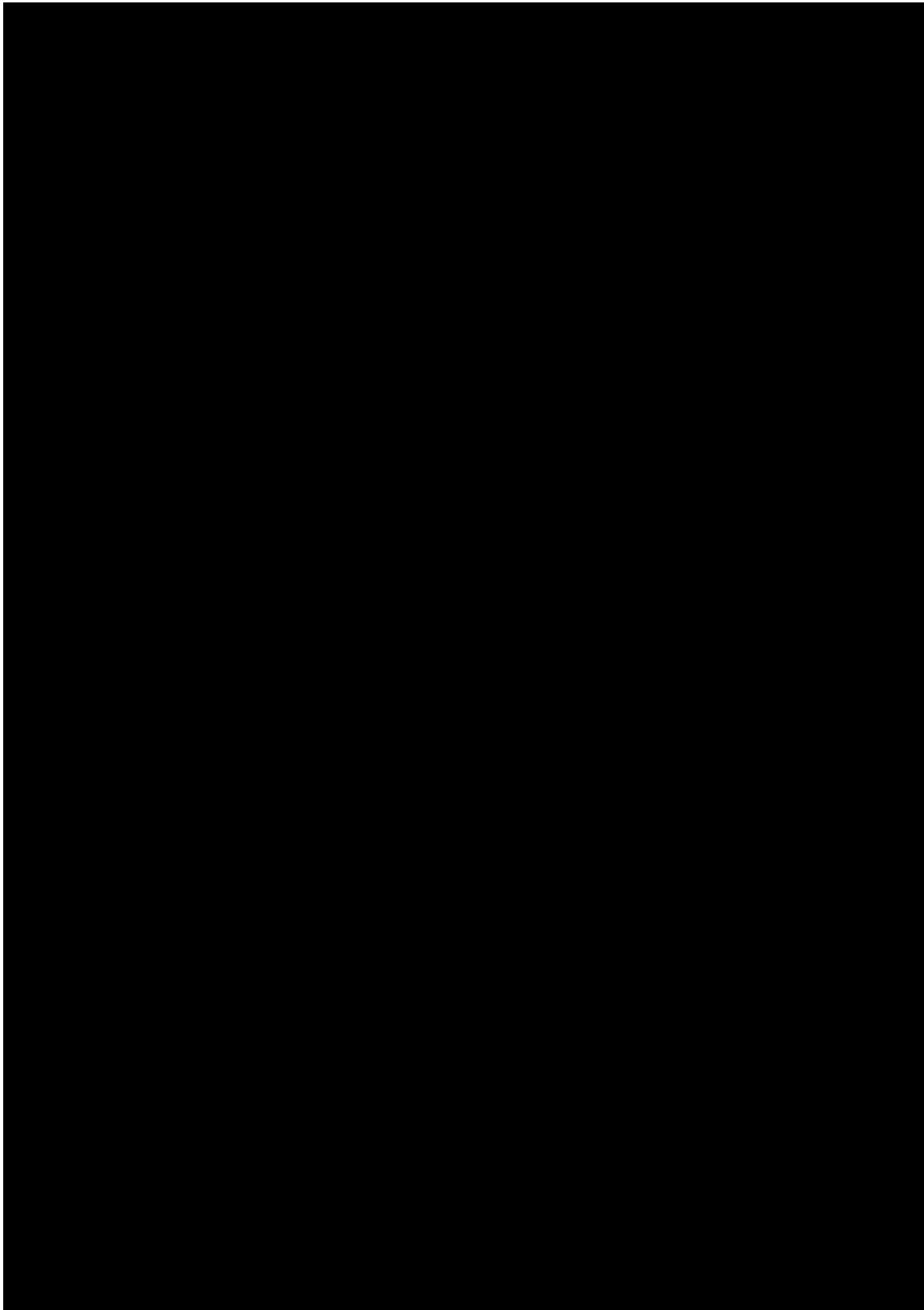

5.3 Manual Mode

The AT-AUTO is world-class manual tuner. *Manual* mode is selected by momentarily pressing the “Mode” pushbutton until the AT-AUTO display shows “Manual Mode” (See Figure 5.2).

During *Manual* mode operation, the user provides control inputs via the “Tune-Select” rotary knob/pushbutton to the AT-AUTO microprocessor, which then actuates the stepper motors and repositions the inductor and capacitor. The position of the capacitor, inductor and the selected output are constantly displayed to the user, such as shown in Figure 5.2.

Figure 5.2: Example Manual Mode Display

By observing the Forward and Reflected power on the AT-AUTO cross-needle display, and by simple manipulation of the “Tune-Select” knob the user is afforded the ability to readily effect manual tuning of the AT-AUTO. Furthermore, when interfaced with a radio that also provides control of an external tuner such as an Icom (AH-4), or Kenwood (AT-300), the radio’s external tuner control circuitry provides the AT-AUTO with a means of radio hardware control and may be used to produce a low-power RF carrier to facilitate tuning the AT-AUTO.

The user may momentarily press the radio’s **TUNER** button when initiating manual tuning. The radio’s **TUNER** button signals the AT-AUTO that a steady low-power carrier is requested. The AT-AUTO then forces the radio to generate a low-level RF carrier (typically 10 W FM). The user then tunes the AT-AUTO by repositioning the *L* and *C* and observing the variation in SWR on the cross-needle meter.

When tuning is complete, the carrier may be stopped by pressing the radio’s **TUNER** button, or the pressing the AT-AUTO “Output” button for 2-3 seconds. If interfaced with an Icom radio with external tuner control, pressing the AT-AUTO “Output” button for 2-3 seconds will toggle the Icom radio’s low-power carrier *On/Off*.

Table 5.2 (page 38) lists the control function provided by each of these three controls when operating in *Manual* mode, and Figure 5.3 on page 39 illustrates the AT-AUTO *Manual* mode process.

T

5.4 Bypass Mode

Bypass mode is selected by momentarily pressing the “Mode” pushbutton until the AT-AUTO display shows “Bypass Mode” (See Figure 5.4). The AT-AUTO *Bypass* mode enables the user to completely bypass RF power around the AT-AUTO RF matching network, while permitting the user to manipulate L and C . *Bypass* mode operation is nearly identical to Manual mode operation, except that the AT-AUTO does not utilize external tuner control provided by some Icom and Kenwood radios.

During *Bypass* mode operation, the user provides control inputs to the AT-AUTO microprocessor via the “Tune-Select” rotary knob/pushbutton, which then actuates the stepper motors and repositions the inductor and capacitor. The position of the capacitor, inductor and the selected output are constantly displayed to the user, such as shown in Figure 5.4.

Figure 5.4: Example Bypass Mode Display

While in *Bypass* mode, repositioning L or C will have NO effect on observed SWR.

Table 5.3 (page 41) lists the control function provided by each of these three controls when operating in *Bypass* mode, and Figure 5.5 illustrates the AT-AUTO *Bypass* mode function.

Note: *Bypass* mode and bypass capability are only possible if the RF bypass hardware is installed in the AT-AUTO. 1st generation AT-AUTOs lacked bypass capability. All current production AT-AUTOs support *Bypass* mode.

Table 5.3: Bypass Mode Control Functions

“Mode” Pushbutton	
Short Duration Press	Selects <i>Automatic</i> mode
Medium Duration Press	No effect
Long Duration Press	No effect
“Tune-Select” Knob	
Short Duration Press	Toggles <i>C/L</i> control
Medium Duration Press	If <i>L</i> Active: Causes <i>L</i> to turn continuously If <i>C</i> Active: Causes <i>C</i> to home to 000
Long Duration Press	If <i>L</i> Active: Causes <i>L</i> to home to 000 If <i>C</i> Active: No effect
Clockwise/counter-clockwise Rotation	Increase/decrease capacitance or inductance
“Output” Pushbutton	
Short Duration Press	Toggles RF Output (Coax/Balanced)
Medium Duration Press	No effect
Long Duration Press	No effect
“Duration” Definition	
Short	\leq 1 second
Medium	2-3 Seconds
Long	\geq 10 seconds

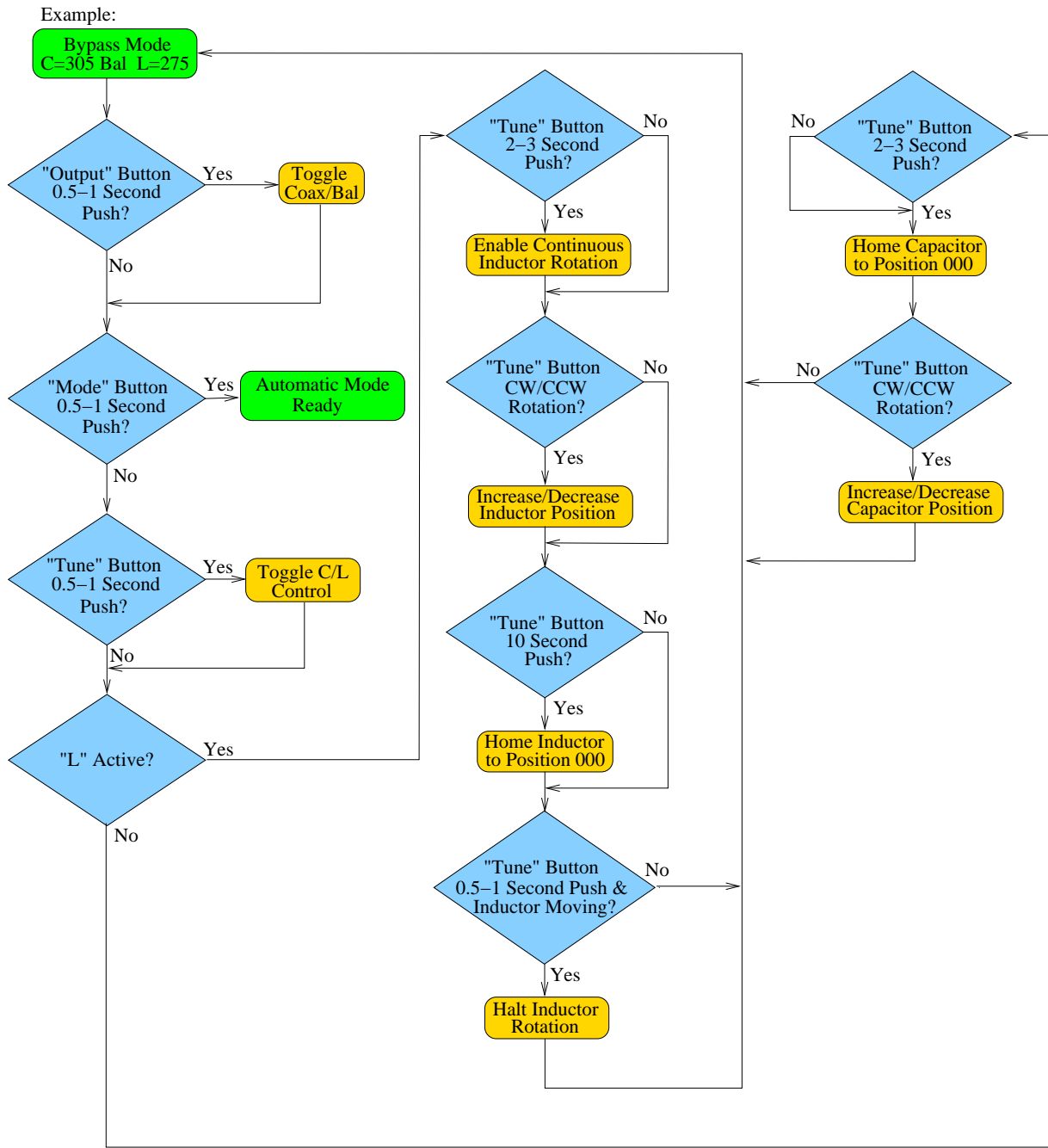

 AT-AUTO Display

Figure 5.5: Bypass Mode Process

Chapter 6

AT-AUTO_{KL} QRO Keyline

The Palstar AT-AUTO_{KL} is identical to the AT-AUTO except for additional hardware that enables the AT-AUTO_{KL} to automatically permit/inhibit keying of an HF amplifier. Use of the QRO Keyline hardware is entirely *optional* and completely independent of the automatic tuning process. It does not otherwise change or alter the operation of the AT-AUTO or AT-AUTO_{KL}.

The user may configure the AT-AUTO_{KL} to automatically prevent the amplifier from being keyed if the SWR exceeds a user-selectable level, or if the AT-AUTO_{KL} is tuning. This may be particularly advantageous when using the AT-AUTO_{KL} with HF amplifiers that feature SWR protection circuitry. If the user neglected to unkey the amplifier while the AT-AUTO_{KL} is tuning, the amplifier's self-protection circuitry would likely disable the amplifier, necessitating a reset of the amplifier itself.

The QRO Keyline hardware enables the AT-AUTO_{KL} to unkey the amplifier if a pre-determined SWR threshold is exceeded, or *prior* to initiating automatic tuning, and the re-enable keying of the amplifier *after* automatic tuning is completed.

6.1 Retrofitting to Older AT-AUTOs

The *optional* QRO Keyline hardware may be retrofitted to the AT-AUTO at the owner's expense. The retrofit involves replacement of the original processor board, installation of an additional cable harness, fitting two RCA phono connectors to the back panel, and recalibration of the A/D converters. The retrofit is only available through the Palstar factory in Piqua, Ohio. Owners wishing to have the QRO Keyline retrofitted should contact Palstar directly for pricing and scheduling.

6.2 Electrical Connection and Setup

Figure 6.1 shows a simplified illustration of the QRO Keyline hardware. The Keyline interface consists of a normally-open SPST relay which is controlled by the AT-AUTO_{KL}'s

microprocessor.

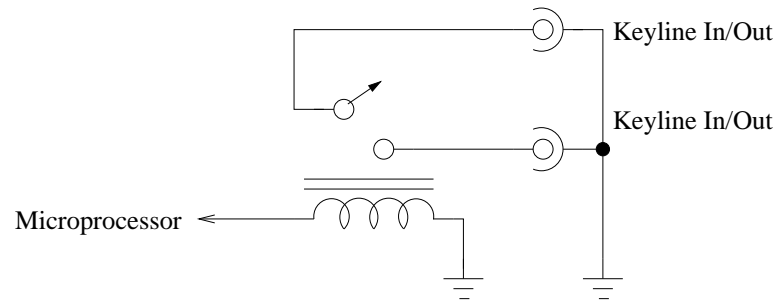

Figure 6.1: QRO Keyline

The (QRO Keyline) relay contacts connect directly to two phono jacks located on the rear panel of the AT-AUTO_{KL}, labeled “QRO Keyline. The transmitter’s amplifier control (“keying”) line is connected to either one of the AT-AUTO_{KL} QRO Keyline jacks. The HF amplifier’s transmit control line is then connected to the remaining AT-AUTO_{KL} QRO Keyline jack as shown in Figure 6.2. The QRO Keyline relay is always *Open* whenever the AT-AUTO_{KL} is *Off*, and as determined by QRO Keyline firmware configuration selected by the user.

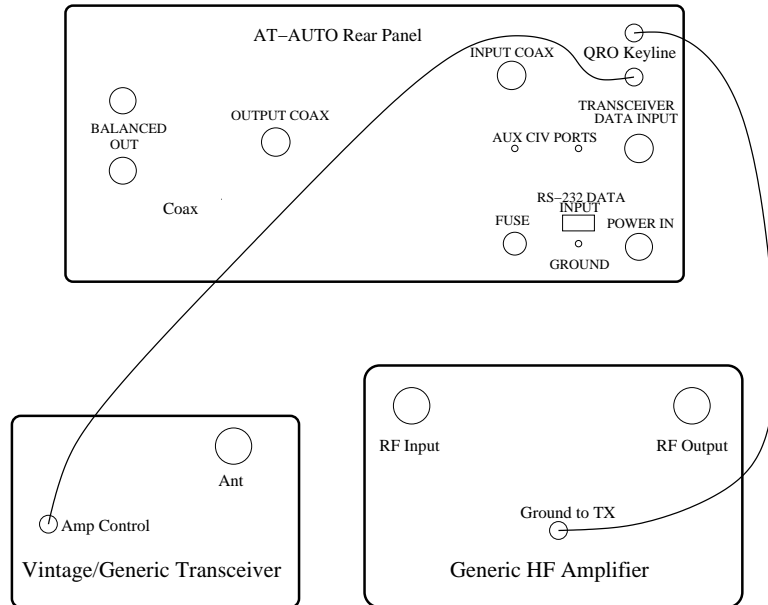

Figure 6.2: QRO Keyline Connections (Other Connections Omitted for Clarity)

6.3 Firmware Configuration

The QRO Keyline is disabled by default. Configuration changes made to the QRO Keyline have absolutely *No* affect on overall tuner operation. If the optional QRO Keyline hardware is not installed, leave QRO Keyline disabled in the firmware.

Access to the QRO Keyline configuration is made through the *Service Menu*. To enter the *Service Menu*, follow the procedure described on page 48 and select the “Configure QRO” option. A secondary menu tree will open (See Figure 6.3). The user may configure the AT-AUTO QRO Keyline to:

1. Always Enable/Disable QRO.
2. Enable QRO Only if SWR \leq User Threshold (*Automatic* and *Manual* modes only).
3. Enable/Disable QRO when tuning (*Automatic* and *Manual* modes only).

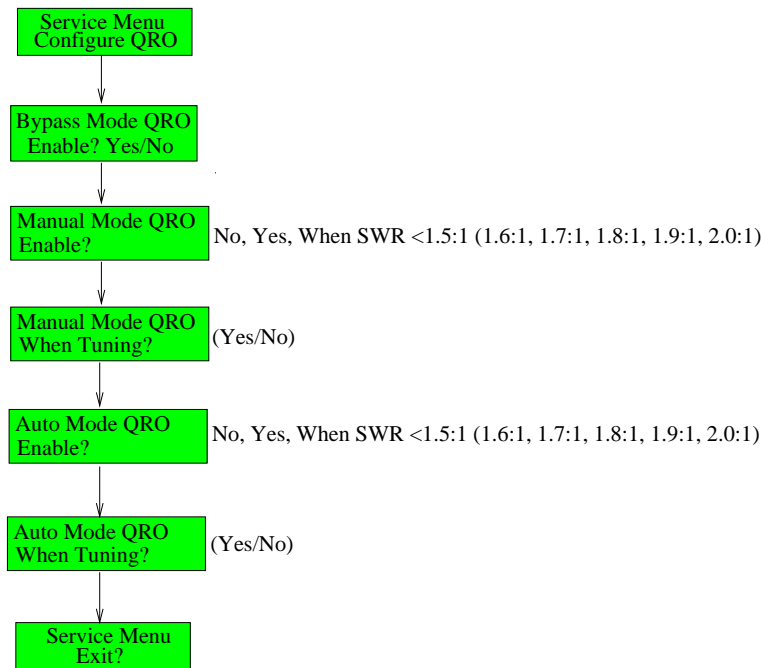

Figure 6.3: Firmware Configuration of QRO Keyline

6.4 Operation

The QRO Keyline control automatically enables or disables keying of an HF amplifier based upon user-selectable criteria. Whenever the QRO Keyline is enabled, an asterisk will be displayed in the upper-right corner of the LCD as shown in Figure 6.4.

The asterisk provides confirmation to the user that the QRO Keyline is enabled (asterisk displayed) or disabled (no asterisk displayed).

Whenever “QRO Enable?” is set to *No* the QRO Keyline is continuously disabled.

Whenever “QRO Enable?” is set to *Yes*, the QRO Keyline is enabled, regardless of SWR.

Whenever an SWR threshold is selected (such as “SWR \leq 1.5:1”), the AT-AUTO will disable the QRO Keyline whenever the SWR exceeds 1.5:1 and the QRO Keyline will not be re-enabled until after the carrier has dropped and the SWR is below a hysteresis value of approximately 1.2:1.

Whenever “QRO Enable When Tuning?” is set to *No*, the AT-AUTO will disable the QRO Keyline immediately prior to positioning the *L* or *C* and it will remain disabled until approximately 2 seconds after the last movement of the *L* or *C*.

Regardless of the particular configuration/operation of the QRO Keyline, neither the *Automatic*, *Manual*, or *Bypass* mode operation is affected by the action of the QRO Keyline.

Figure 6.4: Automatic Mode with QRO Keyline Enabled

Chapter 7

Firmware Configuration

7.1 General Description

The AT-AUTO firmware permits tailoring the AT-AUTO's behavior to better suit the users' specific requirements. The user may configure the AT-AUTO firmware via the AT-AUTO's service menu which is accessed from the AT-AUTO front-panel controls. This section of

7.3 Accessing the Service Menu

User-selectable firmware options are accessed through the AT-AUTO firmware service menus. These menus and sub menus are fairly self-explanatory but are described in this and subsequent sections. The various settings are all selected and controlled from the front panel “Tune-Select” knob. Different menus are accessed by turning the rotary “Tune-Select” knob and options are selected or enabled/disabled by momentarily pressing the “Tune-Select” knob.

Follow these steps to access the service menu:

1. Turn *ON* the AT-AUTO.
2. Place the AT-AUTO in *Automatic* mode.
3. Press and hold the “Mode” button for 10 seconds and then release.

The AT-AUTO will display:



Figure 7.1: LCD Display - Service Menu Exit Prompt.

The service menu configuration options are shown in Figure 7.2 (page 50). To access the various sub menus, merely rotate the “Tune-Select” knob in either direction. When the desired sub-menu item is displayed, momentarily depress the “Tune-Select” knob. Whenever “Exit?” is displayed, momentarily pressing the “Tune-Select” knob will exit that particular menu. Some sub-menus will exit automatically after running through all of the user options.

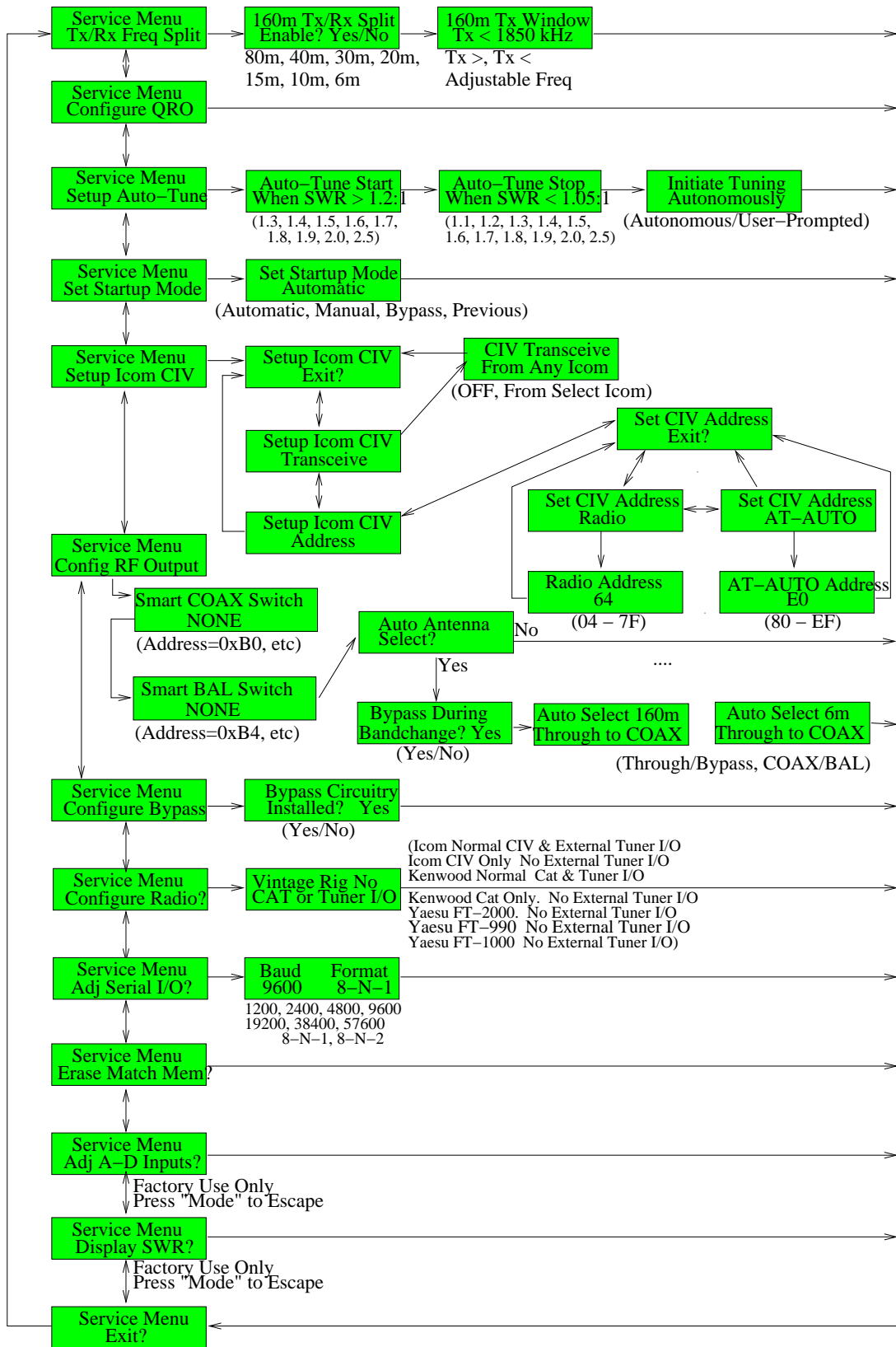

Figure 7.2: Setup: Firmware Options and Flowchart.

7.3.1 Setup Auto-Tune

The AT-AUTO autonomously commences tuning whenever the SWR exceeds the “Tune Start SWR” (default 1.2:1) and halts tuning whenever the SWR falls below the “Tune Stop SWR” (default 1.05:1). The default thresholds are very aggressive as the AT-AUTO will attempt to tune whenever the SWR exceeds 1.2:1 and will not stop tuning until the SWR is less than 1.05:1.

The user may prefer other tune starting and stopping thresholds, particularly if the antenna is subject to significant variations in resonance such as might be encountered with a long-wire antenna being blown around in a strong wind. The SWR tuning thresholds are user selectable.

The user may set the “Tuning Start SWR” from between 1.1:1 to 2.5:1 and the “Tuning Stop SWR” from between 1.05:1 to 2.0:1. The firmware prevent selection of a tuning-stop SWR that exceeds the tuning-start SWR.

The user may also disable autonomous tuning initiation by configuring the AT-AUTO to require operator concurrence before commencing automatic tuning – This is particularly useful is the user wishes to prevent autonomous tuning commencement when using an RF linear amplifier.

To configure the automatic tuning SWR thresholds as well as enable/disable autonomous tuning initiation, from the “Service” menu, follow these steps:

1. Turn the front-panel “Tune-Select” knob until Figure 7.3 is displayed.



Figure 7.3: Automatic Tuning Menu

Table 7.1: Supported SWR Tuning Thresholds

Tune Start	Tune Stop
SWR $\geq 1.2 : 1$	SWR $\leq 1.05 : 1$
SWR $\geq 1.3 : 1$	SWR $\leq 1.1 : 1$
SWR $\geq 1.4 : 1$	SWR $\leq 1.2 : 1$
SWR $\geq 1.5 : 1$	SWR $\leq 1.3 : 1$
SWR $\geq 1.6 : 1$	SWR $\leq 1.4 : 1$
SWR $\geq 1.7 : 1$	SWR $\leq 1.5 : 1$
SWR $\geq 1.8 : 1$	SWR $\leq 1.6 : 1$
SWR $\geq 1.9 : 1$	SWR $\leq 1.7 : 1$
SWR $\geq 2.0 : 1$	SWR $\leq 1.8 : 1$
SWR $\geq 2.5 : 1$	SWR $\leq 1.9 : 1$
	SWR $\leq 2.5 : 1$

Now select the SWR level at which tuning is considered successful and automatic tuning should cease by rotating the “Tune-Select” knob until the desired SWR level is displayed. Then momentarily press the “Tune-Select” knob. This will save this setting in nonvolatile memory and the display will then advance to permit disabling/enabling (default) autonomous tuning initiation.

The user may disable autonomous tuning initiation by selecting “User-Prompted”. When “User-Prompted” is selected, the AT-AUTO will provide a warning to the user and will not start tuning without an input from the user. Rotate the “Tune-Select” knob until the desired tuning initiation option is displayed and then depress the “Tune-Select” knob. The selection will be saved and the display will return to the exit prompt as shown in Figure 7.1.

7.3.2 Set Startup Mode

When powered *On*, the AT-AUTO enters *Automatic* Mode by default. The user may configure the AT-AUTO to instead enter either *Manual* or bypass *Bypass*, or the mode last in use when the AT-AUTO was turned *Off*. To set the startup mode, from the service menu, rotate the “Tune-Select” knob until the display matches Figure 7.4 and then momentarily press the “Tune-Select” knob. The startup mode submenu will open and display the current startup mode setting. Rotate the “Tune-Select” knob until the desired startup mode is displayed. When the desired startup mode is displayed, momentarily press the “Tune-Select” knob and that setting will be saved. The user is then returned to the service menu exit prompt as shown in Figure 7.1.

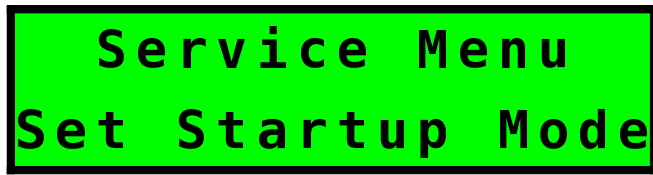

Figure 7.4: Startup Mode Menu.

7.3.3 Setup Icom CI-V

This submenu is only applicable if the AT-AUTO is connected to a CI-V equipped Icom radio, or if intending to remotely control the AT-AUTO. If not, then this section should be ignored.

The AT-AUTO default mode of operation (with Icom radios) is to receive and decode CI-V frequency broadcast data from any CI-V equipped Icom radios operating in the “data transceive” mode. The AT-AUTO listens for frequency information sent over the CI-V serial data bus and then positions the inductor and capacitor to settings appropriate to the operating frequency. The CI-V data transceive operation is completely passive on the part of the AT-AUTO. Refer to your applicable Icom radio manual for further details on CI-V data transceive operation.

When connected to the CI-V bus, the AT-AUTO responds to frequency changes made on any Icom radio (set for “data transceive” operation) attached to the CI-V bus. If there are multiple Icom radios setup for “data transceive” operation and attached to the CI-V bus, the AT-AUTO will respond (by default) to any frequency changes made on any of the radios.

It is possible to limit the AT-AUTO response to just a single Icom radio in data transceive mode by setting the AT-AUTO to follow CI-V data from a specific radio address only. The AT-AUTO can also be setup to query a specific Icom radio based upon the radio’s CI-V address. If the user turns the CI-V transceive to *OFF*, the AT-AUTO will no longer listen or respond to any CI-V frequency data generated from a CI-V data transceive operation. Instead, the AT-AUTO will query the specific radio (based upon the radio CI-V address) at approximately 1 Hz intervals and only responds to frequency data addressed directly to the AT-AUTO from the specific radio. Valid Radio CI-V addresses are in the range of 0x04 to 0x7F and the AT-AUTO may be assigned an address in the range of 0x80 to 0xEF. In order for the AT-AUTO to transmit over the CI-V bus, the internal jumpers on the AT-AUTO controller board must be configured correctly. See Table 14.1 on page 86 for details.

The immediate menu and sub-menu options are shown in Figure 7.2 on page 50. Rotate the “Tune-Select” knob to scroll to the desired menu option and then select the desired option by momentarily pressing the “Tune-Select” button. To setup the Icom CI-V options, from the service menu, rotate the “Tune-Select” knob until the display matches Figure 7.5



Figure 7.5: Setup Icom CI-V Menu.

7.3.4 Configure RF Output

The AT-AUTO firmware is capable of controlling external Coaxial and Balanced antenna switches. These antenna switches are controlled via CI-V or RS-422 inputs. The external antenna switches are nearing completion and should be available starting Winter 2009. Details will be posted on the Palstar website.

The AT-AUTO may be configured to automatically select (based upon operating frequency) either tuner output (coaxial or balanced) and to route the RF through, or to bypass the tuning network when connected to a radio with a compatible CAT/CI-V data port. If the Palstar external Coaxial or Balanced antenna switches are attached, the AT-AUTO can also automatically select any 1-of-8 coaxial outputs or 1-of-4 balanced outputs.

During bandchanges the AT-AUTO may also temporarily bypass the RF matching network while the inductor and capacitor are being repositioned for the new operating band. When this option is enabled, the bypass relay will be energized (RF bypasses the RF matching network) while changing from band to band and will automatically de-energize when the inductor and capacitor are finished being repositioned for the new band. If the user has selected a particular band for automatic bypassing either to the Coax or Balanced outputs, the inductor and capacitor will not be repositioned while operating in this band. Automatic antenna and RF bypass/through selection is only possible if your radio has a compatible CAT/CI-V data port

7.3.5 Configure Bypass

All recent production AT-AUTOs have RF bypass capability. Unless you own an older version of the AT-AUTO which lacks bypass capability, leave this option set to the factory

default (bypass circuitry installed). AT-AUTOs without bypass hardware should be set to “No” (bypass circuitry not installed).

7.3.6 Configure Radio

If the AT-AUTO is properly interfaced to a compatible CAT/CI-V equipped radio, the AT-AUTO may be setup to follow any frequency changes in the radio and automatically preset *C* & *L* based upon match settings for the new frequency. The AT-AUTO can also be controlled by radios with supported external tuner I/O control. In order to enable either of these features, the AT-AUTO must know what type of radio it is connected to as well as the CAT/CI-V serial data rate. Table 7.2 lists CAT/CI-V radios currently supported by the AT-AUTO firmware. This is not all-inclusive.

Table 7.2: AT-AUTO Compatible CAT/CI-V Radios

Make	Model	Select
Elecraft	K2	“Kenwood CAT Only, No Ext Tuner I/O”
	K3	“Kenwood CAT Only, No Ext Tuner I/O”
Flex Radio	SDR-1000	“Kenwood CAT Only, No Ext Tuner I/O”
	FLEX-5000	“Kenwood CAT Only, No Ext Tuner I/O”
Icom	IC-735	“Icom CIV Only, No Ext Tuner I/O”
	IC-706 - IC-7000, etc.	“Icom Normal CIV & Ext Tuner I/O”
	IC-7700/7800	“Icom CIV Only, No Ext Tuner I/O”
Kenwood	TS-480	“Kenwood Normal CAT & Tuner I/O”
	TS-570	“Kenwood Normal CAT & Tuner I/O”
	TS-2000	“Kenwood Normal CAT & Tuner I/O”
TenTec	Omni VII	“ TenTec Omni VII/Jupiter”
	Jupiter	“ TenTec Omni VII/Jupiter”
Yaesu	FT-450	“Yaesu FT-2000 No Ext Tuner I/O”
	FT-920	“Yaesu FT-920 No Ext Tuner I/O”
	FT-950	“Yaesu FT-2000 No Ext Tuner I/O”
	FT-980	“Yaesu FT-2000 No Ext Tuner I/O”
	FT-990	“Yaesu FT-990 No Ext Tuner I/O”
	FT-1000, etc.	“Yaesu FT-1000 No Ext Tuner I/O”
	FT-2000, FT-9000 etc.	“Yaesu FT-2000 No Ext Tuner I/O”

To configure the firmware for a particular make/brand of radio, from the “Service” menu, follow these steps:

1. Turn the front-panel “Tune-Select” knob until the display shows:

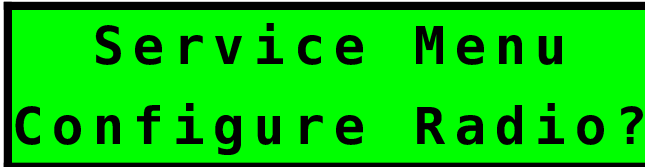

Service Menu
Configure Radio?

2. Momentarily press the “Tune-Select” knob.

The AT-AUTO will then display the currently selected radio type. The supported radio capabilities are shown in Table 7.3. Rotate the “Tune-Select” knob until the appropriate setting for your particular radio is displayed. Then momentarily press the “Tune-Select” knob. This will cause your particular selection to be stored into nonvolatile memory and the display will return to the exit menu as shown in Figure 7.1

Table 7.3: Supported Radio Capabilities

Type	Capability
Elecraft K2/K3	QSY Following Only
Flex Radio SDR-1000/Flex-5000	QSY Following Only
Icom Normal	QSY Following & External Tuner Control
Icom CI-V Only	QSY Following Only
Kenwood Normal	QSY Following & External Tuner Control
Kenwood CAT Only	QSY Following Only
TenTec	QSY Following Only
Vintage Rig	No QSY Following, No External Tuner Control
Yaesu	QSY Following Only

Note: If you are using an older-style radio without a compatible CAT/CI-V or external tuner interface, you should configure the AT-AUTO to operate with a “Vintage Rig” (default).

Note: Flex Radio SDR-1000 should be configured as “Kenwood CAT Only”

7.3.7 Configure AT-AUTO Serial Interface

This section only applies if using a CI-V/CAT-equipped radio. The AT-AUTO serial port configuration must match the serial data rate and number of stop bits used by the radio. The AT-AUTO supports serial data rates from 1200 to 57,600 baud. All serial data bytes are 8-bits long, no-parity and either one or two stop bits (8-N-1 or 8-N-2). The default settings are 9600 baud, 8-N-1. Most radios use one stop bit, but some Yaesu radios utilize 2 stop bits.

To configure the AT-AUTO serial interface, from the initial the “Service” menu, follow these steps:

1. Turn the front-panel “Tune-Select” knob until the display shows:



2. Momentarily press the “Tune-Select” knob.

The AT-AUTO will display the currently selected data rate and type. The supported data rates are shown in Table 7.5 and suggested data rates and types known to work are shown in Table 7.4. Rotate the “Tune-Select” knob until the desired baud rate and number of stop bits is displayed. Then momentarily press the “Tune-Select” knob. This will cause your particular selection to be stored into nonvolatile memory and the display will return to the exit menu as shown in Figure 7.1

Table 7.4: Suggested Serial I/O Settings

Radio Model	Baud	Protocol	Notes
Elecraft K2/K3	9600	8-N-1	Uses Kenwood Protocols
Flex Radio SDR-1000	9600	8-N-1	Uses Kenwood Protocols
Flex Radio FLEX-5000	9600	8-N-1	Uses Kenwood Protocols
Icom IC-735	1200	8-N-1	Radio Hardwired to 1200 Baud
Icom (Most Models)	9600	8-N-1	See Note 1
Kenwood (Most Models)	9600	8-N-1	Common Default Setting
	4800	8-N-2	See Note 2
TenTec Omni VII & Jupiter	57,600	8-N-1	
Yaesu FT-450	9600	8-N-1	See Note 2
Yaesu FT-920	4800	8-N-2	
Yaesu FT-950	4800	8-N-1	Radio Default is 4800 Baud
Yaesu FT-980	4800	8-N-1	Radio Default is 4800 Baud
Yaesu FT-990	4800	8-N-2	
Yaesu FT-1000	4800	8-N-2	
Yaesu FT-2000	4800	8-N-1	Radio Default is 4800 Baud
Yaesu FT-9000	4800	8-N-1	Radio Default is 4800 Baud

Note 1: Will work with any of the Icom radio's Baud rates. Radio and AT-AUTO Baud must be set to same speed. 9600 Baud is a good compromise – especially if sharing the CI-V bus with multiple data devices.

Note 2: Various Baud and number of stop bit settings are available on several radio models via user menus. Radio and Tuner Baud and number of stop bits must match.

Table 7.5: Serial Data Configuration Options

Baud	Protocol
1200	8-N-1
2400	8-N-1
4800	8-N-1
9600	8-N-1
19200	8-N-1
38400	8-N-1
57600	8-N-1
1200	8-N-2
2400	8-N-2
4800	8-N-2
9600	8-N-2
19200	8-N-2
38400	8-N-2
57600	8-N-2

7.3.8 Erase Match Memory

This option will erase all user match settings and restore the memories to factory defaults. Select this option and momentarily depress the “Tune-Select” knob.

7.3.9 Adjust A-D Inputs?

Factory use only. Momentarily press the “Mode” knob to return to the configuration menus.

7.3.10 Display SWR?

Factory use only. Momentarily press the “Mode” knob to return to the configuration menus.

7.3.11 Configure QRO

This is only applicable for the AT-AUTO_{KL} (an AT-AUTO with the optional QRO Keyline hardware installed). AT-AUTO owners should leave set to default settings (“QRO Enable? NO”) for *Automatic*, *Manual*, and *Bypass* modes. See page 43 for detailed description and configuration with AT-AUTO_{KL}.

7.3.12 Tx/Rx Freq Split

The AT-AUTO is capable of following frequency information provided by the radio’s CAT/CI-V port. Under normal circumstances, the AT-AUTO will follow *ALL* frequency changes and reposition *L* and *C* accordingly. However when utilizing separate and distinct transmit and receive frequency “windows”, it is impractical and undesired for the AT-AUTO to reposition *L* or *C* whenever the radio switches from transmit to receive. The AT-AUTO can be user-configured to “ignore” any frequency changes in the receive frequency window, yet to automatically call up match settings whenever the radio’s transmit frequency changes. See page 61 for detailed description and configuration.

Chapter 8

Split-Frequency Operation

The AT-AUTO normally responds to all frequency information provided by the radio's CAT/CI-V serial interface. Split frequency setup permits the AT-AUTO to respond selectively only to serial data pertaining to frequency changes made within a specific frequency range, while ignoring frequency changes made outside of the intended transmit frequency window. Split operation is popular when working DX on 40m for example. European stations may be transmitting voice at the bottom of the 40m band, but listening to North American stations transmitting on the middle-to-upper end of the 40m band.

Once the AT-AUTO has found a good match on the transmit frequency, it would be inconvenient for the AT-AUTO to then automatically re-adjust the L and C away from the transmit frequency match settings whenever the transceiver switches from transmit to receive on a different frequency.

After the "Tx/Rx Freq Split" menu has been selected from the setup menus, the user will then be prompted to enable or disable split frequency operation (to selectively ignore receive frequencies) for the 160, 80, 40, 30, 20, 15, 10, and 6m bands. Figure 8.1 shows the 160m split enable/disable selection window. Rotate the *mode-select* knob to enable (*Yes*) or disable (*No*), then momentarily depress the *mode-select* knob to select that option. The selection process will cycle through all of the available bands.

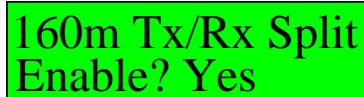

160m Tx/Rx Split
Enable? Yes

Figure 8.1: Transmit/Receive Split Enable (160m)

The user will be prompted to enable/disable split frequency operation for each of the bands (160, 80, 40, 30, 20, 15, 10, and 6m). If the user enabled 160m split operation for example, the AT-AUTO will then prompt the user to select the boundary between the desired 160m transmit and receive frequency (define the “transmit window”) as shown in Figure 8.2.

**160m Tx Window
Tx < 1850 kHz**

Figure 8.2: 160m, 1800-1850 kHz Transmit Window Setup

As depicted in Figure 8.2, the transmit frequency on 160m will be from 1800-1850 kHz (low transmit window) . The AT-AUTO will only follow CAT/CI-V frequency changes within the transmit window range of 1800-1850 kHz, but will not reposition *L* or *C* for any changes made in the receive window (1850-2000 kHz). The transmit/receive window frequency boundary may be changed by rotating the *Tune-Select* knob and the transmit/receive window may be swapped by momentarily pressing the *Mode* button. Figure 8.3 shows a high transmit window from 1872 to 2000 kHz.

**160m Tx Window
Tx > 1872 kHz**

Figure 8.3: 160m, 1872-2000 kHz Transmit Window Setup

Note: Even if split frequency operation had been selected, whenever the radio changes to a different band, the AT-AUTO will initially reposition *L* and *C* to settings appropriate to the new frequency regardless of whether that frequency is within the transmit or receive frequency window. However, subsequent frequency adjustments within the band, but outside of the transmit window will be ignored.

Chapter 9

Firmware Update Guide

Your Palstar AT-AUTO features field upgradeable firmware that can be updated from anywhere you have a PC with an Internet connection and an RS-232 serial port. Follow these steps to update your AT-AUTO with the latest firmware version.

1. Ensure AT-AUTO's internal hardware jumpers are configured correctly (See Table 14.1 on page 86).
2. **Completely disconnect the "Transceiver Data" and any CI-V connections at the rear of the AT-AUTO!! Failure to do so *WILL* corrupt the uploaded firmware, causing the process to fail and possibly corrupting the installed bootloader, requiring that the AT-AUTO processor be reprogrammed at the Palstar factory.**
3. Download "Palstar - Firmware Uploader" software from our website at:
<http://www.palstar.com/at-auto.php>
4. Place the downloaded software into a folder on your PC desktop or hard drive.
5. Unzip the software. It is now ready to use.
6. Connect your AT-AUTO to your PC's RS-232 serial port with the Palstar-supplied "Firmware Upload Cable" (See Figure 10.1 on page 70).
7. Turn *On* your Palstar AT-AUTO.
8. Locate the "Firmware Uploader" software and double click on the Palstar - Firmware Uploader icon to start the software

18. Your firmware is now updated.
19. To check for future firmware updates, click on “Check new version” or visit Palstar.com

9.1 Hardware Requirements for Firmware Updating

The AT-AUTO must be directly connected to a PC’s RS-232 serial port. Due to the stringent timing requirements between the firmware uploading program and the AT-AUTO microprocessor, only a genuine RS-232 serial port will work. **USB to Serial converters have generally proven to be unsuitable for uploading AT-AUTO firmware.**

The PC serial port is often labeled “COM1”, “COM2”, etc. Some newer computers no longer come with RS-232 serial ports included, but add-on cards are available that plug directly into the computer’s PCI bus and provide one, two, or more RS-232 serial port(s). If your computer does not have a serial port, these cards can be purchased relatively inexpensively from your local computer hardware supplier.

The serial cable used for the firmware update must include the “RTS” (Request to Send) handshake line. The Palstar-supplied serial cable is intended for this purpose. For further details, see Figure 10.1

Note: The computer printer port, often labeled “LPT” or “Printer” is a NOT a serial port and is absolutely NOT compatible with the RS-232 protocol. Make NO attempt to use the printer port to update the AT-AUTO firmware - damage to your computer may result.

Chapter 10

Rear-Panel Pinouts and Interface Cables

10.1 Radio Tuner Handshake

The AT-AUTO is capable of controlling the low-power, constant carrier generation capability built into some Icom and Kenwood radios. This “Handshake” mode of operation requires connection of the AT-AUTO with either the Icom’s “tuner” interface or the Kenwood’s “AT” interface. Do NOT attempt AT-AUTO - radio interfacing via the “Data/Handshake” connector with non-Icom or non-Kenwood radios. Kenwood radios require additional external circuitry (built into the Palstar-supplied interface cable) in order for the handshake feature to operate. Figure 10.1 on page 70 illustrates the handshaking cables used for Icom and Kenwood radios.

10.2 Radio/Computer Serial Data Interface

The AT-AUTO interfaces with a computer’s serial port in order to upload new firmware, and in order to enable PC remote control of the AT-AUTO. The AT-AUTO also incorporates unique operating enhancements that are only available when properly interfaced to a (firmware supported) CI-V/CAT capable transceiver.

The AT-AUTO is directly compatible with most popular transceivers via its CI-V (Icom) interface and RS-232 interface (Kenwood, Yaesu, TenTec, & Elecraft rigs). The AT-AUTO is NOT directly compatible with CAT radios that use TTL data levels. In this case, the owner will need to supply an RS-232 to TTL level converter. Connecting the AT-AUTO’s RS-232 serial output to a radio that expects TTL voltage levels will very likely damage the radio. Palstar is not liable for damage caused by improper tuner to radio interfacing.

Palstar supplies an interface cable that is suitable for use with either Icom transceivers, most Kenwood, some Yaesu, several TenTec and Elecraft transceivers. The information supplied in this section is provided to enable the AT-AUTO owner to construct interface cables suitable for his particular model of radio. Rear panel connector pinouts are provided in Table 10.1 on page 69, and Figure 10.1 (page 70) provides illustrations of the serial data interfacing cabling.

Note: When interfacing the AT-AUTO with CAT capable radios via the RS-232 port, Pin 7 (AT-AUTO processor reset) must remain unconnected, or the “Reset Enable” jumper must be *Open* (See Figure 14.1 on page 85).

Note: When interfacing the AT-AUTO with an Elecraft radio via the radio’s I/O port, Pins 7 & 8 must on the remain unconnected or internal damage to the radio may occur.

Table 10.1: Rear Panel Connector Descriptions

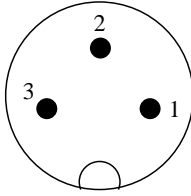
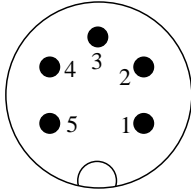
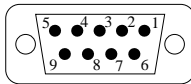
Outline	Name	Pinout
	Power	Pin 1 - No Connection Pin 2 - +12 VDC (≈ 3.5 A max while tuning) Pin 3 - DC Ground
	Transceiver Data	Pin 1 - TTL I/O Pin 2 - TTL I/O Pin 3 - No Internal Connection* Pin 4 - Signal Ground Pin 5 - Icom CI-V Bus I/O (Open Collector)
	RS-232/CAT**	Pin 1 - No Connection Pin 2 - Serial Data Output (From AT-AUTO) Pin 3 - Serial Data Input (To AT-AUTO) Pin 4 - No Connection Pin 5 - Signal Ground Pin 6 - No Connection Pin 7 - AT-AUTO Processor Reset Pin 8 - No Connection Pin 9 - No Connection

***Note:** Some Palstar-supplied Icom interface cables include a wire which is connected between Pin 3 of the Transceiver Data Input and Pin 3 of Icom Tuner plug. However, within the AT-AUTO, there is no internal connection to Pin 3 of the Transceiver Data Input.

****Note:** Voltages are RS-232 compliant and are NOT TTL compatible. If the intended radio uses TTL signal levels, a Level Converter is required. Consult your owner's manual prior to connecting to this port.

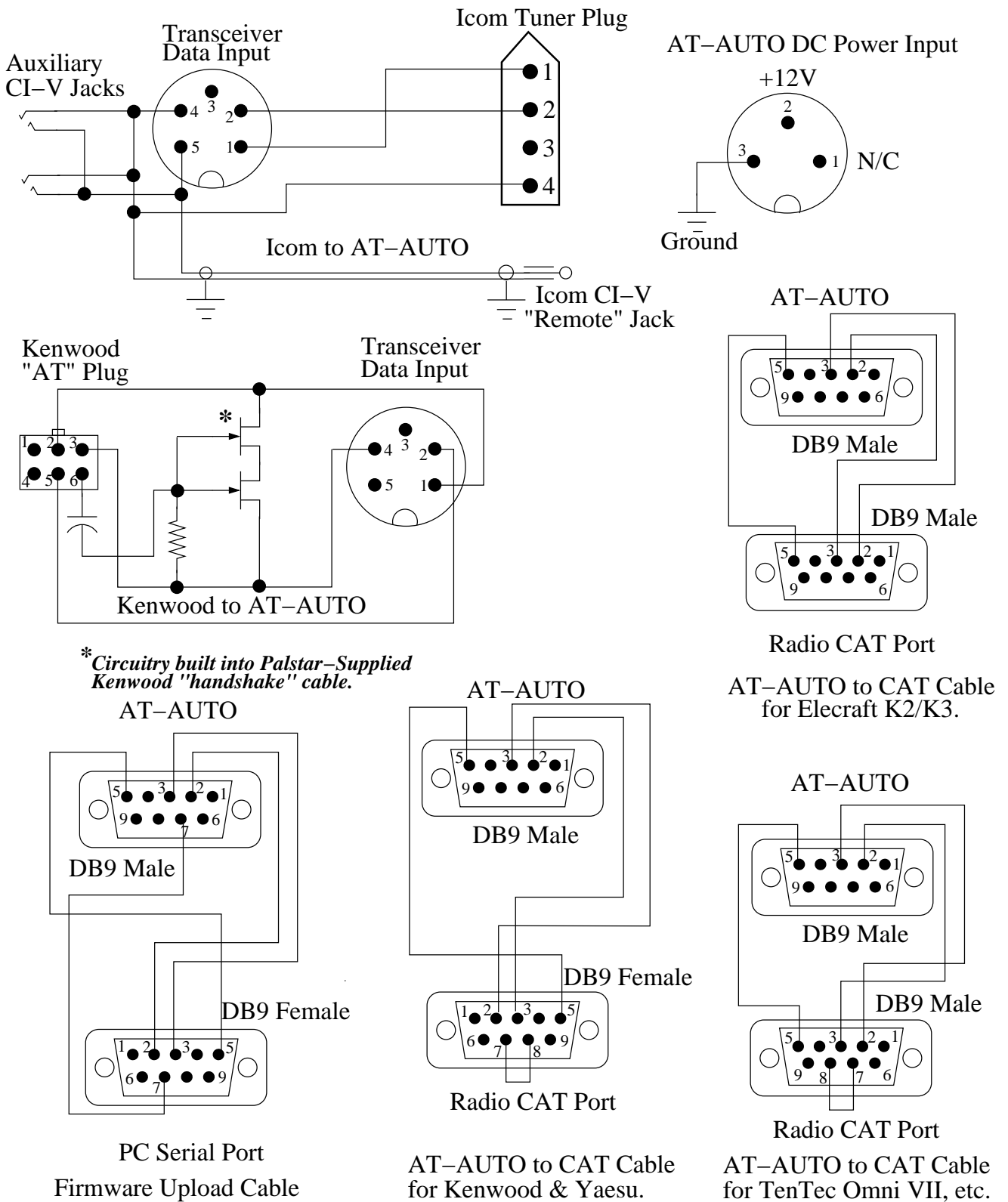

Figure 10.1: Interface Cable Diagrams

10.3 Radio/Computer Serial Data “Y” Interface

The RS-232 protocol used by many CAT transceivers is only designed to connect two serial data devices together – One master device (the AT-AUTO) and one slave device (the HF transceiver). Each device has a dedicated data transmit line which is connected to the other devices’ data receive line. Each serial data line can only have one data transmitting device.

The AT-AUTO and HF transceivers work well together via the RS-232 serial interface. However, logging and control software have become very popular and in many shacks, the HF transceiver simply must be connected to the PC (via the RS-232 serial interface). The “Y” serial data cable should enable the AT-AUTO to listen-only to the serial data sent from an HF transceiver to the PC. So long as the PC sends the appropriate frequency query command to the HF transceiver, and the AT-AUTO is able to receive and decode the frequency data information sent by the HF receiver back to the PC, frequency following by the AT-AUTO should still work as intended.

Figure 10.2 on page 72 is provided so that the user may implement the “Y” data cable interface and attempt to enable AT-AUTO frequency following in those instances when the HF radio must be connected to the shack PC.

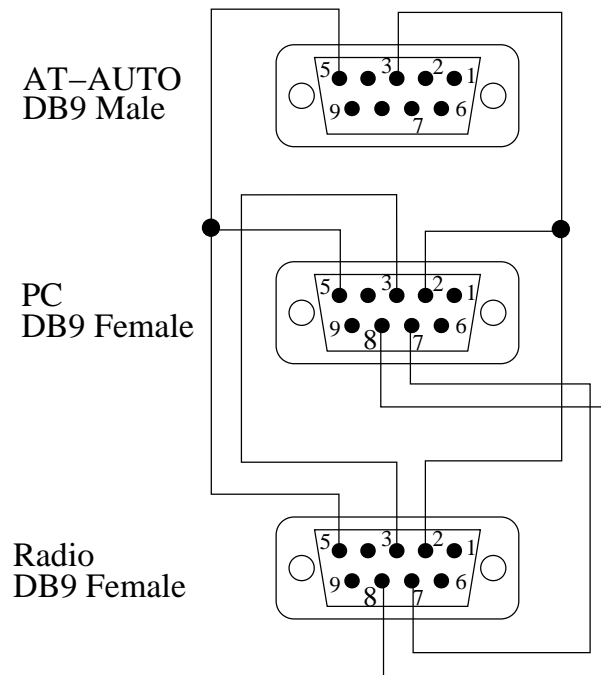

Figure 10.2: Radio/Computer Serial Data “Y” Interface Cable Diagrams

Note: Although some users report success with the “Y” serial data cable, Palstar makes no claim that it will work for your particular application.

Note! Some radios do NOT provide data headers in their serial data strings which causes erratic frequency following whenever non-frequency serial data is sent by the HF transceiver. The Yaesu FT-990 and FT-1000 are known to cause erratic frequency following by the AT-AUTO when using a “Y” serial data cable. Users report success with the FT-2000 and Kenwood radios.

Chapter 11

Remote Control

11.1 General Description

The AT-AUTO is remotely controllable from a computer serial port, or via the Icom CI-V bus, and the AT-AUTO command syntax has been designed to be compatible with the Icom protocols.

The AT-AUTO has a specific CI-V address (default 0xE0) (hexadecimal). The AT-AUTO will ignore any commands not addressed specifically to it. Additionally, all commands should originate from a specific CI-V address, that is different from the AT-AUTO CI-V address. Any of the AT-AUTO's commands may be sent to the AT-AUTO, regardless of its current operating mode (*Automatic*, *Manual*, or *Bypass*).

In order to enable remote control operation, the AT-AUTO must be configured to operate with either an "Icom Normal CI-V & Tuner I/O" or "Icom CI-V Only...". If the radio that the AT-AUTO is connected to is NOT an Icom model, select "Icom CI-V Only...". Additionally, ensure that the AT-AUTO's internal hardware jumpers are configured appropriately (See Table 14.1 on page 86).

All commands are preceded by two identical header bytes (0xFE), and then followed by one trailer (end-of-command) byte which is always 0xFD. All commands are therefore of this format (commas added for clarity only):

0xFE, 0xFE, To-Address, From-Address, Command, Command-Sub Byte(s), 0xFD. The AT-AUTO command set is shown in Table 11.1 on page 75.

Note: When controlling the AT-AUTO, the CI-V From-Address *MUST NOT* be identical to the radio's CI-V. The AT-AUTO *WILL* ignore any commands sent to it from the radio (anytime the From-Address matches the radio's CI-V address).

11.1.1 Example Command Strings

The controlling PC may be assigned any CI-V address. For these examples, assume that the controlling PC is assigned a CI-V address of 0x3A.

To command the AT-AUTO to switch to *Manual* mode, the PC must send the following command string:

0xFE 0xFE 0xE0 0x3A 0x07 0x01 0xFD

The AT-AUTO will switch to *Manual* mode and acknowledge the command by sending:

0xFE 0xFE 0x3A 0xE0 0xFB 0xFD.

Likewise, to remotely select the *Balanced* RF output, the command from the PC would be:

0xFE 0xFE 0xE0 0x3A 0x08 0x10 0xFD

The AT-AUTO will immediately switch to the *Balanced* RF output and acknowledge the command by sending:

0xFE 0xFE 0x3A 0xE0 0xFB 0xFD

11.1.2 Sub-Command Structure and Data Syntax

Generally, most commands include sub-command data bytes. For example, when commanding a Capacitor position, the position is encoded into the command string. Sub-command bytes are always encoded as Binary-Coded-Decimal (BCD). Failure to encode them in BCD format will corrupt the command decoding and the command will fail.

The sub-command data (frequency, *C* or *L* position, etc.) encoded in BCD format, is transmitted LSB (least significant byte) first. For example, to command *C* to position of 274, the position (sub-command) bytes would be 0x74, and 0x02. The command string would therefore be:

0xFE 0xFE 0xE0 0x3A 0x09 0x74 0x02 0xFD.

The QSY command involves sending frequency information to the AT-AUTO. The AT-AUTO will recall match settings for that frequency and automatically position *C* and *L* to their corresponding match positions. For example, to QSY the AT-AUTO to 28.725,168 MHz, the command string would be:

Table 11.1: Remote Control Command Set

Command	Command String (Header + the following string + Trailer)
QSY	0x05 BCD0 BCD1 BCD2 BCD3 BCD4
Read Status	0x06 0x05
Read Power	0x06 0x06
Set <i>Automatic</i> Mode	0x07 0x00
Set <i>Manual</i> Mode	0x07 0x01
Set <i>Bypass</i> Mode	0x07 0x02
Select Coax	0x08 0x00
Select Balanced	0x08 0x10
Home <i>L & C</i>	0x0B
Set <i>C</i> (0-397)	0x09 BCD-Lo BCD-Hi
Set <i>L*</i> (0-13,120)	0x0A BCD-Lo BCD-Hi
Fine Tune	0x0C

Note*: The position displayed in the LCD is the actual inductor position divided by 16. Valid range of inductor position is 0-13,120 (Shown on the LCD as 0-820).

0xFE 0xFE 0xE0 0x3A 0x05 0x68 0x51 0x72 0x28 0x00 0xFD.

The AT-AUTO will respond to a “Read Status” command with the following string:

0xFE, 0xFE, 0x3A, 0xE0, 0x06, 0x05, Output, Mode, Motor, L-Position, C-Position,
Status, 0xFD

Definitions of the information returned after a “Read Status” command are contained in Table 11.2.

Table 11.2: AT-AUTO Response to Read Status Command

Byte	Value/Bit Definitions
Output (Selected Output)	0x00 - Through to Coax 0x10 - Through to Balanced 0x80 - Bypass to Coax 0x90 - Bypass to Balanced
Mode (Active Mode)	0x00 - <i>Automatic</i> Mode 0x01 - <i>Manual</i> Mode 0x02 - <i>Bypass</i> Mode
Motor (Stepper Motors)	Bit 7 - Set if <i>C</i> is commanded to a specific position Bit 6 - Set if <i>C</i> is turning Bit 5 - Always Clear/No Meaning Bit 4 - Set if <i>L</i> is commanded to a specific position Bit 3 - Set if <i>L</i> is turning Bit 2 - Always Clear/No Meaning Bit 1 - Set if <i>C</i> movement was/is Clockwise Bit 0 - Set if <i>L</i> movement was/is Clockwise
Inductor Position*	3 Bytes in BCD format. Example: 8,926 – 0x26 0x89 0x00
Capacitor Position	2 Bytes in BCD format. Example: 257 – 0x57 0x02
Status	0x00 - Stepper motors commanded to stop 0x01 - <i>Automatic</i> mode idle 0x02 - Automatic tuning in progress 0x03 - Match not found 0x04 - Match found, $SWR \leq$ “Tune Stop SWR”, saving match settings 0x05 - Match found, $SWR \leq$ “Tune Start SWR”, saving match settings 0x06 - Automatic mode QSY in progress 0x07 - Automatic tuning aborted/timed out

Note*: The position displayed in the LCD is the actual inductor position divided by 16. Valid range of inductor position is 0-13,120 (Shown on the LCD as 0-820).

The AT-AUTO uses four 10-bit hardware analog-to-digital converters. Two of the A/D converters are used to provide high SWR resolution when operating at low RF input power levels. Likewise the remaining two A/D converters are used when using high RF input power levels, when the low-power A/D converters would likely be saturated. If specific SWR information is required, the user's particular computer application may calculate SWR from the A/D converters. The output of the A/D converters is relative and not absolute. If specific power calibration is required, this may also be accomplished with custom user application software. The AT-AUTO "Read Power" command returns the conversion results for all four A/D converters in the following format:

0xFE, 0xFE, 0x3A, 0xE0, 0x06, 0x06, Forward-High, Reflected-High, Forward-Low, Reflected-Low, 0xFD

Definitions of the individual bytes returned from a "Read Power" command are contained in Table 11.3.

Table 11.3: AT-AUTO Response to Read Power Command

Power (2 Bytes Each)	Value
Forward Power High (0-1024)	Example: 374 - 0x74 0x03
Reflected Power High (0-1024)	Example: 12 - 0x12 0x00
Forward Power Low (0-1024)	Example: 927 - 0x27 0x09
Reflected Power Low (0-1024)	Example: 36 - 0x36 0x00

Chapter 12

Analog Power Meter

The AT-AUTO cross-needle Power/SWR meter is derived from the popular Palstar PM2000A and is capable of reading peak-envelope-power (PEP) in SSB mode. The Wattmeter is provided as an operator convenience and the AT-AUTO controller circuitry is completely independent from the Wattmeter circuitry. The Wattmeter also has an operator-selectable dual-range power level switch (300 W or 3000 W). Wattmeter switch settings have no effect on operation of the AT-AUTO.

12.1 Reading Peak Power

The **LAMP** button controls both the SWR meter illumination as well as power to the **PEAK** and **PEAK/HOLD** circuitry. It must be *On* in order to read peak power. Depressing the front panel **PEAK** button will activate the active peak power circuitry and the meter will display PEP and exhibit fast attack and approximately 1.5 second delay time. The displayed PEP will be approximately 95-100% of the SSB signal PEP, but may vary depending upon the tonal and inflection characteristics of the user's voice (displayed power may be greater). If the **PEAK/HOLD** button is depressed, the maximum PEP measured will be "held" on the meter display for approximately two seconds. This feature is provided to make it easier to observe the actual peak output power.

For CW signals, the peak power is synonymous with average power. Therefore, a transmitter's single tone (CW) signal should yield the same displayed power level regardless of whether the meter is set to display the average or peak power (switch selection set to **AVG** or **PEAK**, respectively).

Note: The **PEAK/AVG** switch must be depressed in order for the **PEAK/HOLD** feature to function properly.

12.2 Calibration

The meter was calibrated at the Palstar factory. However, it may be calibrated with the following procedure:

1. Connect the AT-AUTO coaxial output to another calibrated Wattmeter of known accuracy.
2. Terminate the output of the calibrated Wattmeter into a 50 Ω dummy load.
3. Set the AT-AUTO to *Bypass* mode.
4. Deselect the **PEAK/HOLD** feature.
5. Turn *On* the meter **LAMP** (to supply DC power to the meter circuitry).
6. Calibrate the low-range **AVG** forward power display
 - (a) Set the AT-AUTO Wattmeter to the 300 W power range.
 - (b) Set the AT-AUTO Wattmeter to read **AVG** power.
 - (c) Connect the output of an HF transmitter to the AT-AUTO RF input.
 - (d) Apply an approximate 100 W CW carrier to the AT-AUTO.
 - (e) Adjust the **FOR LO** potentiometer (Figure 12.1, page 81) so that the AT-AUTO's forward power indication matches that shown on the calibrated Wattmeter.
7. Calibrate the low-range **PEAK** forward power display
 - (a) Set the AT-AUTO Wattmeter to read **PEAK** power.
 - (b) Apply an approximate 100 W CW carrier to the AT-AUTO.
 - (c) Adjust the **PEAK LO** potentiometer (Figure 12.1) so that the AT-AUTO's forward power indication matches that shown on the calibrated Wattmeter.
8. Calibrate the high-range **PEAK** forward power display
 - (a) Set the AT-AUTO Wattmeter to the 3000 W power range.
 - (b) Apply an approximate 500-1000 W CW carrier to the AT-AUTO.
 - (c) Adjust the **PEAK HI** potentiometer (Figure 12.1) so that the AT-AUTO's forward power indication matches that shown on the calibrated Wattmeter.

9. Calibrate the high-range **AVG** forward power display
 - (a) Set the AT-AUTO Wattmeter to read **AVG** power.
 - (b) Apply an approximate 500-1000 W CW carrier to the AT-AUTO.
 - (c) Adjust the **FOR HI** potentiometer (Figure 12.1) so that the AT-AUTO's forward power indication matches that shown on the calibrated Wattmeter.
10. Reverse the AT-AUTO coaxial input and output (connect transmitter output to AT-AUTO coaxial output, connect AT-AUTO coaxial input to calibrated Wattmeter, which terminates into a 50 Ω dummy load.
11. Calibrate the high-range reflected power display
 - (a) Apply an approximate 20-50 W CW carrier to the AT-AUTO.
 - (b) Adjust the **REV HI** potentiometer (Figure 12.1) so that the AT-AUTO's reflected power indication matches the forward power displayed on the calibrated Wattmeter.
12. Calibrate the low-range reflected power display
 - (a) Set the AT-AUTO Wattmeter to the 300 W power range.
 - (b) Apply an approximate 10-20 W CW carrier to the AT-AUTO.
 - (c) Adjust the **REV LO** potentiometer (Figure 12.1) so that the AT-AUTO's reflected power indication matches the forward power displayed on the calibrated Wattmeter.

Figure 12.1: Meter Board Adjustment Locations

Chapter 13

Operating Tips

13.1 QRO Operation

When using a high-power amplifier with the AT-AUTO, the AT-AUTO would occasionally attempt to retune during SSB transmissions. This problem was addressed in firmware version 2.0, and testing shows that the problem is greatly mitigated. However, to prevent this from happening, the user may disable “Autonomous” automatic tuning (See Configuration Section), or else select *Manual* mode after the AT-AUTO has successfully completed the automatic tuning attempt.

13.2 CI-V Passive Listening

When the AT-AUTO is configured to support Icom CI-V radios but is also set to CI-V Transceive *Off*, it will periodically send frequency query commands to the Icom transceiver. The Icom transceiver will then respond by sending its frequency data back to the AT-AUTO.

Whenever multiple controllers attempt to control (query) the same transceiver, data collisions are much more likely to occur. These data collisions may corrupt the frequency data that was sent over the CI-V bus and could sometimes result in erratic/erroneous AT-AUTO frequency-following. Although this was an infrequent problem with early generation AT-AUTO firmware, the AT-AUTO firmware has since been greatly improved to better detect and ignore data collisions. In the very unlikely event that data collisions are causing erratic AT-AUTO frequency following errors, you may try the following:

The solution is to ensure that only one device (AT-AUTO or computer logging software, etc.) is permitted to query the radio for frequency information, while the AT-AUTO, computer software, and any other controller on the data bus merely “listen” for the radio’s

response to the singular frequency queries.

For example, if the user has a computer logging program which accesses the CI-V bus and queries the radio at regular intervals, the user may reduce the likelihood of CI-V data bus collisions by preventing the AT-AUTO from querying the radio, and preventing the radio from autonomously placing uncommanded data on the CI-V bus (set data transceive to *Off*). The AT-AUTO will now follow frequency information sent as a result of a query generated by the computer logging program. In this case, the user should set the AT-AUTO CI-V address to match the CI-V address of the computer running the logging program, and CI-V transceive to *Off*. With the AT-AUTO's "CI-V query enable" jumper removed, the AT-AUTO's query attempt will never reach the CI-V bus. It will only be able to listen for CI-V data but will not transmit on the CI-V bus. The Icom radio should then also be set to data transceive *Off*. Conversely, if the computer logging software can be configured to listen only, the the AT-AUTO may be setup to provide the radio frequency queries.

Alternatively, if using an Icom CI-V equipped radio, configured for data transceive *On*, the radio will automatically send frequency data anytime its frequency changes. All of the other controllers (AT-AUTO, computer, etc.,) should be configured to receive only. In this manner, data collisions are prevented because the radio is the only device placing data on the serial databus. All other devices are passive listeners.

13.3 CAT Passive Listening

In order for the AT-AUTO to follow frequency changes in CAT-equipped radios, it must receive frequency data from the radio (normally in direct response to the AT-AUTO's querying of the radio's frequency). The radio's response may also be generated as a result of computer logging software generating the radio query command. The user may fabricate a serial "Y" cable, whereby the AT-AUTO's serial data transmit line is omitted, but where the serial data line from the radio is shared between the computer and the AT-AUTO. The AT-AUTO and the computer will both be able to receive the radio's frequency data, transmitted as a result of the computer-generated query command.

Chapter 14

Internal Jumper Settings

The AT-AUTO has two user-selectable hardware jumpers. The default jumper settings are appropriate for most AT-AUTO applications. Some circumstances may require alternate jumper settings. The jumpers are located on the AT-AUTO controller circuit board and their relative locations are indicated in Figure 14.1 on page 85 . Jumper settings are listed in Table 14.1 on page 86.

14.1 Reset Enable

The AT-AUTO incorporates a microprocessor reset-via-RTS signal from a computer serial port. The software used by the computer to upload firmware to the AT-AUTO microprocessor requires the ability to reset the AT-AUTO microprocessor.

14.2 CI-V Tx Enable

In it's default jumper configuration, the AT-AUTO is able to transmit and receive data over the RS-232 port and receive data from the CI-V bus, but is unable to transmit data over the CI-V bus. This is generally immaterial because when an Icom radio is setup for CI-V data transceive operation, it will automatically send frequency data over the CI-V bus, and does not require the AT-AUTO to transmit data over the CI-V bus or otherwise query the Icom radio. However, if the Icom radio is configured with CI-V data transceive *Off*, then the AT-AUTO must actively query the radio, and the CI-V Tx Enable jumper must be Closed.

14.3 Jumper Access

Remove DC power from the AT-AUTO. Then remove the screws along the left and right sides of the AT-AUTO to remove the top cover. The controller circuit board is located immediately behind the Liquid Crystal Display (LCD). Observe anti-static precautions when working on/near the controller circuit board.

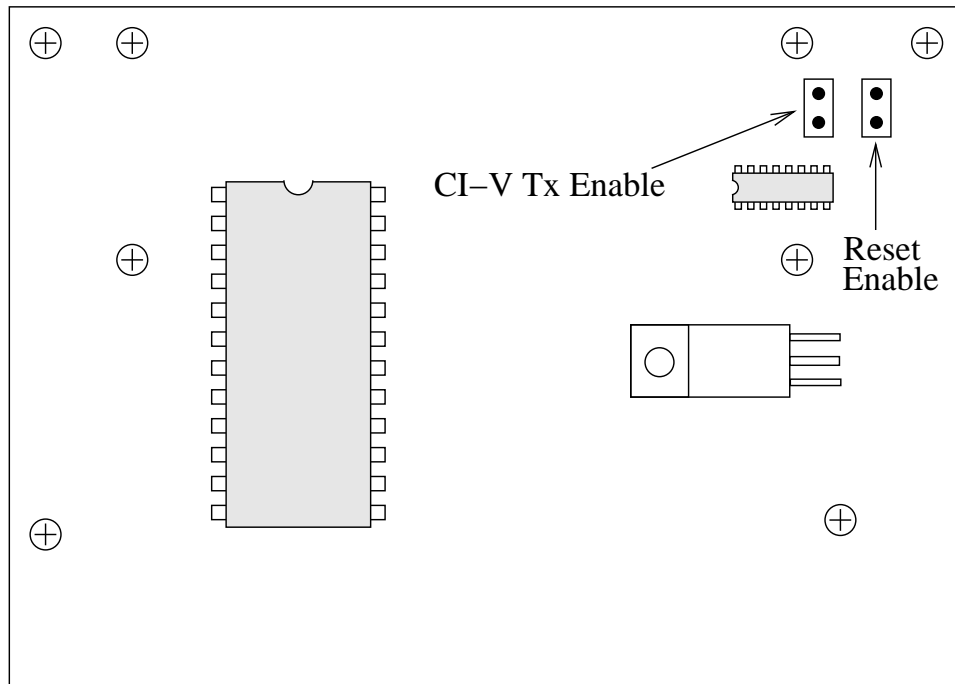

Figure 14.1: Jumper Locations

Table 14.1: Jumper Settings

Operation	Reset Enable	CI-V Tx Enable
CI-V Transceive from Any Icom	Don't Care	Don't Care
CI-V Transceive from Specific Icom	Don't Care	Don't Care
Smart with CI-V Transceive OFF	Open	Closed
Smart via CAT*	Closed	Open
Smart Via CAT**	Open	Open
Firmware Update	Closed	Open
Remote Control via CAT	Open	Open
Remote Control via CI-V	Open	Closed
Default	Closed	Open

***Note:** *Reset Enable* jumper may be Closed if using the “AT-AUTO to CAT” cable illustrated in Figure 10.1 on page 70.

****Note:** *Reset Enable* must be Open if hardware flow control line (RTS) is present in the CAT cable. If unsure, remove the jumper from *Reset Enable*.

Chapter 15

Firmware Revision Summary of Changes

The AT-AUTO was first released with Firmware version 1.01. Firmware versions 1.02 through 1.10 consisted mainly of minor bug fixes and some other minor firmware enhancements. Firmware version 1.10 was the last firmware update prior to version 2.0.

Version 2.0 is significantly different from versions 1.01-1.10, incorporating new operating features and refinements along with a considerable number of minor, not-so-minor, and semi-critical bug fixes. Palstar, Inc. encourages all AT-AUTO owners to update their AT-AUTOs with the latest firmware which as of this writing is version 2.10.

15.1 Version 2.00 Bug Corrections

The following is a partial summary of bugs found in previous firmware versions (in no particular order of significance) and corrected with AT-AUTO firmware version 2.0:

1. Configuration/Data EEPROM write - Bug forced configuration and data settings to be continuously written to EEPROM at a 1 Hz rate. Data should only have been written to EEPROM if the data had changed. This was a hidden bug (now fixed) and was not apparent to user.
2. Non-Initialized Fine Tuning - Bug manifested whenever “fine tune” commanded without prior automatic tuning in the band of operation. Under these conditions, the AT-AUTO would motor the inductor to the maximum inductance and stop.
3. Runaway Inductor - Occasionally during automatic tuning, the Inductor would motor to maximum L and stop.

4. Runaway Capacitor - Occasionally during automatic tuning the Capacitor would repeatedly turn to position 397, then continue to approximately 004, and repeat sequence indefinitely.
5. LCD Blanking - LCD would momentarily blank during auto-tune initiation.
6. Uncommanded/Unintentional retuning while in SSB mode - During SWR/Power sampling AT-AUTO would detect reflected power prior to detection of forward power, causing AT-AUTO to interpret this as excessive SWR and initiate retuning.
7. Failure to recognize excessive SWR - Under some circumstances with very excessive SWR, AT-AUTO would report “Good Match” and fail to initiate automatic tuning despite the very obvious (via the analog meter) antenna mismatch.
8. Frequency Error - Under conditions of very high SWR, AT-AUTO would occasionally be unable to discern the operating frequency from the RF sample. Firmware and hardware changes have considerably improved this problem. Problems might still occur albeit rarely.
9. Autotuning Past Low SWR Points - During automatic tuning, the positioning of L or C was too coarse causing the AT-AUTO to step past good match points. Occasionally the AT-AUTO would then be unable to find a successful match although subsequent matching attempts (manual or automatic) would find suitable matches. Addressed in revised tuning algorithms.

15.2 Version 2.00 New Firmware Features

AT-AUTO firmware version 2.00 includes the following new features:

1. Kenwood CAT support - Provides QSY-following of Kenwood CAT-enabled radios by polling frequency information via the Kenwood CAT (serial data) port (Tested with TS-570D).
2. Yaesu CAT support - Provides QSY-following of the FT-2000 as described above for Kenwood. (Tested with FT-990, and FT-2000).
3. Kenwood Tuner Interface - Enables automatic tuning initiation via the “TUNER” button and “AT” interface present on some Kenwood HF radios (Tested with TS-570D).

4. User-Selectable Startup Mode of Operation - User may select (via firmware configuration menu) the startup mode that the AT-AUTO enters upon initial power-up. User may opt to have the AT-AUTO always startup in either the *Automatic*, *Manual*, *Bypass*, or the mode last in-use when the AT-AUTO was turned-off.
5. Automatic Antenna & Bypass Selection - User may specify which output to automatically select (Coax/Balanced) based upon band of operation as well as whether the RF is to pass through or bypass the tuning network. This feature requires a supported CAT/CI-V equipped radio.
6. Bypass during Band Change - AT-AUTO may be configured to automatically bypass the tuner while the AT-AUTO is changing bands. When enabled, if QSYing from one band to another (40m to 160m for example), the AT-AUTO will route the antenna directly to the radio (RF does not pass through the tuning network) until the *L* and *C* have been repositioned to the band of operation (160m in this example). This feature requires a supported CAT/CI-V equipped radio.
7. Enhanced Icom CI-V transceive operation - The normal (default) AT-AUTO CI-V data transceive scheme is to constantly follow all frequency data sent via the CI-V bus from any CI-V equipped Icom radio. The user may however, configure the AT-AUTO to follow only CI-V transceive frequency data from a specific radio (based upon the radio's CI-V address). Furthermore, the AT-AUTO can be configured to completely ignore CI-V transceive data and to poll a specific Icom radio.
8. Remote Control Operation - The AT-AUTO may be remotely controlled via the Icom CI-V bus. The AT-AUTO CI-V address is user selectable and remote control operation permits the user to:
 - (a) Set specific *L* and *C* positions.
 - (b) Position *L* & *C* by sending frequency data to the AT-AUTO.
 - (c) Select tuner output (Coax/Balanced).
 - (d) Select operating mode (Automatic, Manual, Bypass).
 - (e) Read *L* & *C* positions, as well as forward and reflected power.
 - (f) Home *L* & *C*.
9. Autonomous/Non-Autonomous Tuning Initiation - The AT-AUTO's normal (default) behavior while in *Automatic* mode is to constantly monitor Forward and Reflected

power, calculate and monitor SWR. Then whenever SWR exceeds a set threshold (default 1.2:1 SWR), the AT-AUTO autonomously initiates tuning. The user may now configure the AT-AUTO for “Non-Autonomous” tuning initiation. When so configured, the AT-AUTO continues to monitor Forward & Reflected power and to calculate and monitor the SWR. However, whenever the SWR exceeds a preset threshold (default 1.2:1 SWR), instead of initiating automatic tuning, the AT-AUTO displays a warning to the user. Whenever this warning is displayed, the user may consent to automatic tuning initiation by momentarily press the rotary “Tune-Select” knob. Momentarily pressing the “Tune-Select” knob signals the user’s consent to initiate automatic tuning. This feature was added to provide a means to completely prevent automatic re-tuning, especially when using an HF amplifier.

10. Selectable SWR Tuning Thresholds - While in *Automatic* mode, the AT-AUTO initiates automatic tuning whenever the SWR exceeds 1.2:1 (default). Automatic tuning continues until the SWR is at/below 1.05:1 (default). The user may configure the AT-AUTO to use other SWR thresholds to indicate when tuning should be initiated and at what SWR level automatic tuning should be considered successful. The AT-AUTO’s SWR defaults are quite stringent especially since most other auto-tuners cease tuning when SWR is less than 1.5:1. By setting higher thresholds, a user may opt to minimize retuning when operating with antennas experiencing frequent resonance changes (Example: a long dipole antenna blowing around in a strong wind).

15.3 Version 2.01 Bug Corrections

AT-AUTO firmware version 2.01 includes these changes/corrections:

1. Change to the remote control *C* positioning command - Correct operation required a third position byte (0x00) or else the command failed. Positioning command is now in accordance with the description provided in the operating manual (See Table 11.1).
2. CI-V bus collision detection - In earlier firmware releases, the AT-AUTO would sometimes spontaneously QSY based upon collision-corrupted CI-V bus data, which manifested as an illogical/erroneous QSY frequency. Likewise other bus collisions would occasionally cause erroneous/unintended AT-AUTO remote-control command execution.

15.4 Version 2.01 New Firmware Features

AT-AUTO firmware version 2.01 includes the following new features:

1. Automatic *L* and *C* homing - During installation of firmware version 2.01 (and newer), the AT-AUTO will home *L* and *C*, and then preset *C* to 250.
2. *L* and *C* synchronization tracking - If the user switched the AT-AUTO *Off* before *L* or *C* position information was successfully written to non-volatile memory, then the AT-AUTO will automatically home *L* and *C* when the AT-AUTO is next turned *On*. After completion of the homing operation, *C* will automatically be repositioned to 250.

15.5 Version 2.02 Bug Corrections

AT-AUTO firmware version 2.02 includes these changes/corrections:

1. Delayed CI-V command execution bug in version 2.01 - In version 2.01, CI-V bus collision detection was incorporated by providing a fixed delay between decoding of the command and execution of the command. After the delay, if the CI-V bus jamming sequence (0xFC) had not detected, then the command was executed. However, the very last command was not being executed until the subsequent data string had decoded, causing the the AT-AUTO to be one frequency change behind. This was particularly noticeable when changing bands using the Icom radio's band buttons and was not observed when turning the VFO knob. CI-V data decoding and frequency following is now corrected. This problem did not affect CAT operation with non-Icom radios.

15.6 Version 2.03 Bug Corrections

AT-AUTO firmware version 2.03 includes this change/correction:

1. A bug introduced in version 2.02 effectively disabled frequency following via the CAT port of Kenwood and some Yaesu radios. Version 2.03 fixed this bug, restoring normal CAT operation with the affected radio types. No other changes were made in version 2.03.

15.7 Version 2.04 New Firmware Features

AT-AUTO firmware version 2.04 includes the following new features:

1-800-773-7931

www.Palstar.com

1. Continuous display of the selected RF output (balanced/coax) while in *Automatic* mode.
2. Elimination of the ability of the user to rotate the roller inductor past the '000' position, thereby removing the likelihood that the roller inductor will be driven past the '000' position and strike the physical stop.

15.8 Version 2.05 New Firmware Features

AT-AUTO firmware version 2.05 includes the following new feature:

1. Kenwood and Yaesu serial data header decoding. This improves the operation of the AT-AUTO when used with a "Y" cable configuration when controlling the radio with a computer. This only works with Yaesu radios that provide headers that identify the type of information contained in the serial data string. The Yaesu FT-1000, for example, does not provide this information and thus "Y" cable operation with the FT-1000 is still problematic.

15.9 Version 2.06 Bug Corrections

AT-AUTO firmware version 2.06 includes this change/correction:

1. A bug was found that occasionally affected storage of match settings after "fine tune" had been commanded. Under some very specific circumstances the revised match setting was either not updated in memory, or else an incorrect setting was occasionally stored. The "fine tune" bug affected all previous firmware versions. Version 2.05 contains this bug fix but no other changes.

15.10 Version 2.07 Bug Corrections

AT-AUTO firmware version 2.07 includes this change/correction:

1. A bug was found that affected the initial recall of match settings when switching the RF outputs. This problem only manifested when the AT-AUTO had received frequency information via the CAT/CI-V interface and had subsequently recalled and set the L and C to the appropriate match settings for the selected output (the coax output for example). If the user then switched the AT-AUTO to balanced output for example, the AT-AUTO would not recall and reposition L or C for the balanced output unless

either the frequency was subsequently changed or unless an RF carrier was produced and the AT-AUTO subsequently detected a mismatch. This bug has been corrected. Now whenever the RF output is changed, the AT-AUTO will immediately reposition L and C for the active RF output.

15.11 Version 2.07 New Firmware Features

AT-AUTO firmware version 2.07 includes the following new features:

1. Yaesu FT-920 support. The AT-AUTO firmware now includes the ability to follow frequency changes in the FT-920 via the radio's CAT port.
2. Revised tuning algorithm. The AT-AUTO firmware includes a minor change in the automatic tuning algorithm which improves the likelihood of finding a successful match as well as reduce the time needed to find the match.
3. QRO keyline control. The AT-AUTO firmware now includes provision to enable/disable the keying of an external HF RF power amplifier based upon user-selectable SWR levels. The AT-AUTO_{KL} includes additional hardware necessary to implement QRO keyline control. Additionally, the external amplifier can be prevented from being keyed while the AT-AUTO_{KL} is tuning (*Automatic* or *Manual* mode). Retrofitting this capability to existing AT-AUTOs is possible but requires hardware replacement/modification by Palstar. Contact Palstar for pricing and availability.

15.12 Version 2.08 New Firmware Features

AT-AUTO firmware version 2.08 includes the following new features:

1. TenTec Omni VII and Jupiter CAT support. The AT-AUTO firmware now includes the ability to follow frequency changes in the Onmi VII and Jupiter radios via the radio's CAT port.
2. Control of external Coaxial and Balanced antenna switches. The AT-AUTO will permit selection of any one of eight Coaxial outputs as well any one of four Balanced antenna outputs. The external Coaxial switch and external Balanced switch are recent AT-AUTO accessories. Contact Palstar for pricing and availability.

15.13 Version 2.09 Bug Corrections

AT-AUTO firmware version 2.09 includes these changes/corrections:

1. QRO keyline was sometimes unpredictable when in automatic mode, if the firmware was configured with QRO Enable == Yes, and QRO While Tuning == No. Version 2.09 corrected this.
2. .When configured to automatically bypass a specific band, if several band changes were made in rapid succession, automatic band bypassing was sometimes erratic and unpredictable. This problem has been corrected in version 2.09.

15.14 Version 2.10 Changes

AT-AUTO firmware version 2.10 includes these changes:

1. Corrections to the operation of the QRO Keyline:
 - (a) The QRO keyline required many SWR samples before the keyline would be re-enabled. Version 2.10 improves the responsiveness of the QRO keyline.
 - (b) The QRO keyline would open for frequency changes within a particular band, but would (erroneously) remain enabled when changing from band to band. This problem has been corrected in version 2.10.
2. Changed the Remote Control data returned by the AT-AUTO during "Read Status" and "Read Power" commands to include the Command and Sub-Command identifiers.

15.15 Version 2.11 Bug Corrections

AT-AUTO firmware version 2.11 includes these changes/corrections:

1. QRO keyline Relay chatter: During *Bypass* mode operation, while adjusting the *L* or *C*, the QRO Keyline would momentarily open and close at a very high rate. This is now corrected.
2. QRO keyline erratic operation: During *Manual* mode, with the QRO keyline configured to be permanently enabled ("QRO keyline Enable – Yes"), the keyline would open whenever high SWR was encountered. This problem is now fixed
3. When remotely controlling the AT-AUTO, the LCD did not always display correct information. The LCD operation during remote control operation has been corrected.

15.16 Version 2.11 New Firmware Features

AT-AUTO firmware version 2.11 includes the following new features:

1. Split frequency operation. The AT-AUTO is capable of following frequency information via the radio's CAT/CI-V port and automatically positioning the L and C . However, during split frequency operation it is impractical if the AT-AUTO re-positions L and C whenever switching from the transmit to receive frequency. The firmware is now configurable to enable the AT-AUTO to ignore serial frequency data for the receive frequency window, while responding to frequency changes in the transmit window.
2. Remote control "Fine Tune" command. "Fine Tune" command re-initiates tuning, but uses the present L and C settings. Commanding "Fine Tune" while in Automatic mode, will cause the established L and C match settings to be stored in non-volatile memory. This feature may also be utilized to store user-derived match settings.

Chapter 16

Software License Agreement

IMPORTANT – READ CAREFULLY. Notice to user: To download or read the entire Software End-User License Agreement visit:

<http://www.palstar.com/at-auto.php>

The End User License Agreement (“Software License Agreement”) is a legal agreement between you, the User, and Palstar. By powering on the AT-AUTO and or installing future updates to the AT-AUTO firmware via the Palstar website (www.palstar.com) you agree to be bound by the terms of the Palstar AT-AUTO Software License Agreement including, without limitation, the warranty disclaimers, and limitation of liability. You agree that this agreement is enforceable like any written agreement negotiated and signed by you. If you do not agree, you are not licensed to use the Software, and must destroy any downloaded copies of the Software in your possession or control.

Chapter 17

Service and Warranty

17.1 Limited Warranty

Palstar Inc. warrants products manufactured by it to be free from defects in material and workmanship under normal user and service **for a period of one (1) year for the AT-AUTO (the “Warranty Period”)**. Palstar Inc’s obligation under this warranty is limited to repair or replacement of the product at it’s option at the Palstar factory in Piqua, Ohio.

Effective only when the product is returned to the factory with all transportation charges prepaid and examination of the produce discloses in Palstar’s judgment, to have been defective during the Warranty Period.

The Warranty Period shall not extend beyond its original term with respect to interim in-warranty repairs by Palstar. This Warranty Period shall not apply to any product which has been repaired or altered by anyone other than Palstar without prior written authorization. Warranty does not extend to any products which have been subject to damage from improper installation, application or maintenance in accordance with the operating specification. Palstar neither assumes nor authorizes any person to assume for it any obligation or liability other than herein stated.

17.2 Repair Policy

When sending in a product for service, please “double” box it carefully and ship it insured for your protection. Please include a note clearly describing the problem, how you wish the item returned and how you wish to pay for the service. Package your equipment properly. Palstar, Inc. is not responsible for merchandise damaged in shipment. Our service rate is \$30 per hour ($\frac{1}{2}$ hour minimum).

17.3 Return Policy

All returns must receive prior authorization from Palstar. Returned items must be received in original-AS SHIPPED-condition including the original box, manuals, accessories, and copy of sales receipt. Returns must be within 14 days of purchase. Returned items are subject to a 25% restocking fee. Shipping is not refundable.

Chapter 18

Frequently Asked Questions

This section covers the most frequently asked questions. However, we are also aware of a users group available on Yahoo that many AT-AUTO users have found quite helpful. While Palstar, Inc. is not affiliated with this group, we are certainly aware of its existence and thankful for the very professional manner in which it is run. The URL is:

http://groups.yahoo.com/group/palstar_atauto/

18.1 Serial Port Related Questions

18.1.1 Why is there a serial port on the AT-AUTO?

Does this mean that I can remotely control it? What is the control protocol?

Answer: Remote control operation has been included since Version 2.0 (and subsequent) firmware versions. See “Remote Control” section on page 73 for details.

18.1.2 Will the AT-AUTO work with my Collins KWM1 and others without a computer interface?

Answer: Yes! The AT-AUTO is a fully automatic antenna tuner. It works fine with all HF radios. It includes the CI-V/CAT and external tuner interface circuitry merely as an operating convenience, but they are NOT necessary for automatic tuner operation.

18.1.3 Why does the AT-AUTO have an RS-232 port instead of a USB port?

Answer: The AT-AUTO interfaces with an HF radio and with your computer via a conventional RS-232 port. Most modern HF radios that have CAT capability, do so via an RS-232 serial port (an exception: Icom uses a simple single line, bidirectional, open-collector, serial interface). Using an USB port instead of an RS-232 port in the AT-AUTO would have meant that our customers would need to purchase a USB-RS232 converter in order to achieve the CAT interface capability that the AT-AUTO already provides. The CAT (RS-232) interface is only used to provide low-data-rate frequency information and remote control commands to the AT-AUTO. Depending upon the radio, this data stream may be less than 20-bytes. Clearly the expense and complexity of USB is unwarranted.

18.2 Memory-Related Questions

18.2.1 How can I clear the AT-AUTO memories?

Our local club was conducting an emergency communications drill. I brought my AT-AUTO to the simulated emergency location and want to use the clubs G5RV antenna but a lot of the memories contain match settings for my 160m dipole at home.

Answer: The AT-AUTO firmware includes over 500 non-volatile memories. The memory is split evenly with 250+ memories each for the balanced and coaxial outputs. The memory can be reset to the factory defaults by entering the “configuration” menu, and then scrolling to the “Erase Match Mem?” option and pressing the “Tune-Select” rotary knob.

18.2.2 What happens when I select “Erase Match Mem?” How do the memories work?

Answer: Selecting “Erase Match Mem?” erases all of the users match settings that were stored in the AT-AUTO’s non-volatile memory and restores all 500+ memories to original factory defaults.

The factory defaults are mere starting points for tuning operation based upon operating frequency. Each memory default when “coax” output is selected is for a nominal 50 Ω load. Likewise, the “balanced” output default is for a nominal 200 Ω load. Based upon frequency and selected output, if the SWR exceeds an approximate 1.2 : 1 threshold, the AT-AUTO recalls from memory the respective inductor and capacitor settings and presets them accordingly. Then if the SWR is still excessive and if subsequent tuning occurs and a successful match is found, that memory’s default settings are overwritten with the actual match settings.

18.2.3 Can I manually edit the memory settings?

Answer: Short answer – No.

Long answer – Yes, but only indirectly. The manner in which this may be done is to operate the tuner in manual mode and manually adjust the tuner for a suitable match. Then switch the tuner to automatic mode and command a “fine tune” by momentarily pressing the Mode-Tune rotary knob. The tuner will attempt to fine tune, but finding the good match, will instead store your match settings.

18.2.4 How do I control which memory is recalled and used?

Answer: You really can't - The AT-AUTO manages all of the memories automatically based upon operating frequency and which output is selected.

18.3 Radio-Interfacing Questions

18.3.1 Why doesn't the AT-AUTO work in Smart and Handshake modes with other radios?

Answer: We designed the AT-AUTO to interface with ALL radios that incorporated a CAT/CI-V interface and or included an external tuner interface. Version 2.0 firmware provided Icom, Kenwood, and limited Yaesu support. Support for other radios continues to be expanded and included in newer firmware versions.

The AT-AUTO hardware should be capable of supporting most radios. The decision to support Icom radios first was made because the Icom interfaces are well documented and standardized across the entire Icom transceiver product line. However, we now also support an increasing variety of radios, including Elecraft, Flex, newer Kenwood, several TenTec, and many Yaesu radios, etc.

18.3.2 Will the AT-AUTO automatically follow frequency changes in the IC-735?

Q: I want to use my Icom IC-735 with the AT-AUTO. I know that the IC-735 uses a 4-byte CI-V frequency protocol, whereas newer Icom radios use a 5-byte CI-V frequency protocol. Will the AT-AUTO automatically follow frequency changes in the IC-735? Do I need change the firmware setup?

Answer: You are correct, the earlier Icom radios used 4-byte frequency data, but newer Icom radios pass 5 bytes of frequency data over the CI-V bus. The AT-AUTO works just

fine with both the 4 and 5 byte frequency protocols. However, the IC-735 is (hardware) configured to operate at 1200 baud, whereas most newer Icom radios support a broad range of data rates. To make the AT-AUTO automatically follow IC-735 QSY operations the AT-AUTO must be configured for 1200 baud, and should be setup for Icom "CI-V Only" operation. See the "Configuration" section on page 53 for details.

18.3.3 How can I make the AT-AUTO follow a specific Icom radio in a multi-radio setup?

I have a contest station consisting of multiple Icom IC-756PROIII and IC-7800 radios. These radios are networked via the Icom CI-V bus and under software control from a PC. I have an AT-AUTO working perfectly with one of the PROIII radios. However, the AT-AUTO follows all frequency commands sent from the PC to any of the other radios. For example, when I command the IC-7800 to QSY, the AT-AUTO which is actually connected to a PROIII, changes to the frequency of the IC-7800.

Answer: What you are describing is selective CI-V addressing by the AT-AUTO and has been included in the AT-AUTO firmware since Version 2.0. Please see the "Icom CI-V Configuration" section on page 53 for specific instructions.

18.3.4 Why doesn't "Fine Tune" work with my Collins S-Line?

The AT-AUTO was working just fine with my IC-7000, but there is a problem with the "Fine Tune" feature when I use the AT-AUTO with my Collins S-Line. Basically when using it with the Collins station, pressing the "Mode-Tune" button when in Automatic Mode, produces an error with the AT-AUTO complaining about a no-power abort. Is this a problem with the AT-AUTO?

Answer: When using the AT-AUTO with any radio that lacks CAT/CI-V capability, the AT-AUTO should be configured for "Vintage Rig" via the configuration menu. Please reconfigure the AT-AUTO for "Vintage Rig" and this will solve this problem.

18.4 General Usage Questions

18.4.1 How should I setup the Peak-Hold metering for the AT-AUTO to work automatically?

Answer: The AT-AUTO control circuitry does not use any of the Peak-Hold metering. All circuitry used by the AT-AUTO for manual/automatic tuning is independent of the Peak-Hold metering circuitry. The Peak-Hold circuitry and the SWR meter are included

as an operator convenience only during manual tuning operation and are not used by the AT-AUTO during the process of automatic tuning.

18.4.2 How does the AT-AUTO differ from other automatic tuners available to the amateur radio community?

Answer: This is the ONLY fully-automatic antenna tuner purposefully designed and built to conservatively handle a continuous 1500 W CW carrier. Most other automatic tuners are a mere collection of fixed inductors and capacitors that are switched in/out by relay and as such are generally limited to 600W PEP or less.

The AT-AUTO uses the same high-quality roller inductor and split-stator capacitor used in our highly-acclaimed manual tuners, but they now are adjusted by stepper motors under microprocessor control.

18.4.3 Is this a Ham-Band only tuner? Will this work on the MARS frequencies?

Answer: The AT-AUTO will match antennas operating in the 1.8 - 54 MHz range. There are match memories dedicated to the entire match range of the tuner. Non-volatile memories for MARS frequencies as well as other Federal/Civil frequencies are incorporated into the AT-AUTO firmware.

18.4.4 Why does the AT-AUTO take up to 30 seconds to tune?

Answer: The actual tune time of the AT-AUTO is very fast; 1-3 second tuning time is very typical. The 30 seconds quoted is due to the transit time it takes for the AT-AUTO to reposition the roller inductor from one extreme to another such as QSYing from 160m to 10m.

The actual tuning starts once the inductor and capacitor have been pre-positioned for the frequency/band of operation. When operating in Smart mode, the AT-AUTO automatically recalls its matched settings from non-volatile memory and subsequent tuning is likely not necessary.

18.4.5 Why does the AT-AUTO retune at high power when it found a match at low power?

After I QSY if the SWR is bad, the AT-AUTO gets a low-power carrier from my Icom radio to tune against. The tuning process seems to work fine, but occasionally when I subsequently

transmit, the AT-AUTO starts re-tuning. Why does it do this if it found a match at low power?

Answer: The output of the RF bridge rolls off non-linearly at very low power levels. This is the reason that the AT-AUTO sometimes retunes upon application of QRO although a good match was previously found at QRP levels. The tuning algorithm is intentionally extremely conservative (attempting to match to 1.05:1 or better). At 10 W input to a load matched to 1.2:1 or better SWR, the reflected power levels are indeed very low and approach the hardware's limit to detect these power levels. However, when QRO is applied, the reflective power may be sufficiently increased (even at extremely good SWR) and detected by the AT-AUTO. This is most often manifested when the AT-AUTO is coupled to an radio that is configured to utilize the radios external tuner interface and rely upon the radio to produce a steady 10W carrier. From experience, it turns out that this power level may vary from radio to radio with some radios producing a stronger carrier (fine) (≈ 15 W) while others less ($\approx 6-7$ W) (problematic).

18.4.6 The tuner sometimes retunes after autotuning using the radio's "Tuner" button. Why?

My AT-AUTO seems to work fine if I tune in high power and then operate. However, if I tune using the Tuner button on the Icom radio, the AT-AUTO quite often wants to re-tune once I switch to high power operation. It does this about 30% of the time when using the coax-fed loop, but rarely does this when using a similar loop which is fed directly with ladder line. Why does it do that? Is there something wrong with my AT-AUTO?

Answer: Tuning at low power has a couple of advantages. It reduces QRM and it places less stress on the transmitter while a match is being sought. It is also convenient when using an Icom or Kenwood radio you merely press the rigs' Tuner button and it all happens automatically... However, if there are losses in the antenna system greater than the resolution of the Forward/Reflected power sampling, then tuning might need to be re-accomplished when subsequently operating at higher power output levels.

18.4.7 Why is tuning different depending upon whether using coax-fed or balanced-fed antennas?

OK But Why? And why does it seem to be different depending upon whether it is a coax-fed or balanced-fed antenna?

Answer: Several factors contribute to this behavior, including the power losses within the feed line and feed line connectors, the linearity of the RF sampling network and the bit-resolution of the analog-to-digital converters used to quantify the Forward and Reflected power samples.

The AT-AUTO firmware includes an SWR hysteresis feature. That is, it measures the Forward and Reflected power and if the SWR is less than 1.2:1 (default), then it does not automatically tune. However, if the SWR is determined to be greater than 1.2:1, then automatic tuning is initiated. During the automatic tuning process, the AT-AUTO attempts to improve the SWR to 1.05:1. As soon as an SWR of 1.05:1 (or better) is achieved, the tuning is halted and the match settings are stored. If 1.05:1 (or better) is NOT achieved, the tuning process continues until it times out. At that time, if the SWR is still greater than 1.05:1, but less than 1.20:1, the automatic tuning process is deemed successful and the match settings are stored. The AT-AUTO provides the user with an visual indication of which criterion was met by displaying either “SWR \leq 1.05 : 1” (default) or “SWR \leq 1.2:1” (default), or “Match Not Found.”

The SWR is calculated using the following equation:

$$SWR = \frac{P_{Fwd} + P_{Ref}}{P_{Fwd} - P_{Ref}}$$

Given a Forward power of 10W (as provided when using the “Tuner” button on the radio), an SWR of 1.20:1 is observed if 0.90W of Reflected power is sensed at the SWR bridge. If the Reflected power sensed is 0.95W, the observed SWR is 1.21:1 which now exceeds the hysteresis threshold needed for automatic tuning initiation. Conversely, if the Reflected power sensed is only 0.85W, the observed SWR is 1.19:1. Therefore a variation in Reflected power of 0.05W is all that is required to vary the observed SWR and may initiate automatic tuning. Losses in cables or connectors will easily exceed this threshold.

If a 100W carrier is used for tuning instead, 9W of observed Reflected power will result in a 1.20:1 SWR. Likewise 9.5W of observed Reflected power yields an observed SWR of 1.21:1. The difference now is that it requires an approximate Watt increase in Reflected power to achieve an SWR that exceeds the automatic tuning threshold. Therefore, when tuning at 10W, a 0.05W change in observed Reflected power may be all that is required to vary the observed SWR from 1.20:1 to 1.21:1 (exceeding threshold and triggering automatic tuning). However, when tuning at 100W, a $\frac{1}{2}$ W change in observed Reflected power may be required to vary the SWR around the hysteresis threshold level.

The AT-AUTO is capable of quantifying observed power levels ranging from approximately 5-1500W with a resolution of approximately 0.1W. When tuning with a 10W carrier, this resolution is slightly coarse for differentiating 0.05W variations in observed Reflected power, but is well suited for resolving $\frac{1}{2}$ W variations in observed Reflected power when tuning with a 100 W carrier. While the AT-AUTO power resolution at low power may seem limited, the most detrimental factor is the overall feedline loss and the actual SWR at the antenna feed point. From the ARRL Handbook, the matched losses for several feed lines are Table 18.1: The “matched loss” is the expected power loss due to the resistive and dielectric losses with the feedline when the feedline is terminated in its characteristic impedance. For

Table 18.1: Feedline Match Losses

Feeder Type	Loss per 100'
RG-58	2.25 dB
RG-8	1.25 dB
Open-Wire	0.1 dB

an RG-58 type coaxial cable, if that cable is terminated into a perfect 50Ω load, then for every 100' of feedline, 2.25dB of power loss is expected.

These losses increase significantly if there exists a significant mismatch between the feedline and the intended load. The matched loss in dB is:

$$Loss = 10\text{Log}\frac{P_{Fwd}}{P_{Ref}}$$

For a 100' length RG-58 coaxial cable terminated into a 50Ω load, the expected loss is approximately 40% when operating at 30 MHz. If the input power is 10W, only 5.9W will be supplied to the 50Ω load. Conversely, for a 100' length of Ladder Line, when terminated in its characteristic impedance, the expected loss is only 2.3%! A similar length of RG-8 coaxial cable driving a 50Ω load will dissipate as heat approximately 24% of the transmitter power.

Table 18.2: 100' Feedline Match Loss for 1.0:1 SWR

Feeder Type	Loss (dB)	Power Loss	Power at Antenna
RG-58	2.25 dB	40.4%	59.6%
RG-8	1.25 dB	25.0%	75.0%
Open-Wire	0.1 dB	2.3%	97.7%

When the feedline is NOT terminated in its' characteristic impedance, some power will be reflected back from the load toward the transmitter, increasing the feedline losses. The following table serves to illustrate the observed SWR that would be observed by the AT-AUTO when coupled to various feed lines, and when those feedline terminations produce reflections ($SWR \geq 1.0:1$). This table assumes 100' feedline length, and operation at 30

MHz with 100 W drive power. See the ARRL Handbook for a more detailed explanation and associated equations.

Table 18.3: 100' Feedline Match Loss for various SWR

Feeder	SWR at Ant	SWR at AT-AUTO	Feeder Loss	Power at Antenna
RG-58	1.36:1	1.20:1	41.3 W	58.7 W
RG-58	10.0:1	2.90:1	74.2 W	25.8 W
RG-8	1.27:1	1.20:1	25.5 W	74.5 W
RG-8	10.0:1	4.18:1	39.8 W	60.2 W
Open Wire	1.20:1	1.20:1	2.3 W	97.7 W
Open Wire	10.0:1	8.98:1	10.4 W	89.6 W

Table 18.3 is intended to illustrate that coaxial cables, whi

NOT an autonomous antenna tuner the AT-AUTO is. The AT-AUTO constantly monitors SWR and automatically re-tunes if necessary. The AH-4 only tunes when commanded, and then only tunes to reduce SWR to 1.5:1. The AT-AUTO strives for a much better match of 1.05:1, but a match of 1.2:1 or better is automatically considered a success. The 1.05:1 SWR criteria is much more challenging to achieve, but is readily achievable with the AT-AUTO firmware and variable capacitor and roller inductor. The AH-4 uses lumped capacitance and inductor values which often do not yield sufficiently fine resolution of capacitance and inductance necessary to provide the precise tuning match achieved with the AT-AUTO.

18.5 Firmware-Specific Questions

18.5.1 Does the latest version of the firmware only work with the AT-AUTOs that have the QRO Keyline hardware?

Someone posted a message on one of the user reflectors saying that earlier versions of the AT-AUTO are not upgradeable. Is this true?

Answer: No. By design, *ALL* versions of AT-AUTO firmware work with *ALL* versions of the AT-AUTO. All AT-AUTOs are indeed firmware upgradeable by the user, free of charge. Firmware version 2.07 (and subsequent) merely include an ability to control some *optional* hardware to disable/enable keying of an external HF power amplifier. This and all subsequent firmware versions remain fully compatible with every hardware version of the AT-AUTO. If your AT-AUTO does not include the *optional* QRO Keyline hardware, you should merely leave QRO Keyline disabled in the firmware.

18.5.2 Where can I get a copy of the firmware source code?

I am a software engineer and have experience with the Atmel-type processor used in the AT-AUTO. I would like to add some of my own refinements to the AT-AUTO. Where can I get a copy of the source code?

Answer: The license agreement you accepted when you purchased the AT-AUTO prevents you from accessing, revising, reverse-engineering, sharing, etc., the AT-AUTO firmware. The AT-AUTO firmware is wholly-owned Palstar, Inc. intellectual property. We are protecting it accordingly. Our legal department is poised to take whatever legal action if necessary to do so. You should realize that considerable time and expense has gone into its development. Some of our competitors may very likely attempt to bring similar products to the market, and in so doing attempt to circumvent much of the development costs by copying or otherwise reverse-engineering our firmware. We therefore regret that we are unable to divulge any of the firmware specifics.

18.5.3 Why should I update to the newer AT-AUTO firmware?

Answer: You might not need to, but you will probably want to. When we started design on the AT-AUTO, we understood that the firmware would likely be an “evolutionary” process. We are in good faith attempting to provide a high-quality, effective, QRO, automatic antenna tuner. We knew from the onset that while we invested considerable time and resources into the development of our firmware, there would likely be improvements and enhanced features that we will want to make available to our customers. Additionally, if problems were later discovered and as improved algorithms are designed, we wanted the customer to be able to take advantage of these improvements (at no additional cost).

This is the reason we included the ability to upload the firmware to the AT-AUTO. The design of the AT-AUTO permits us to continually improve the AT-AUTO operation and add new firmware features. We look upon the AT-AUTO as an evolutionary product with sufficient firmware flexibility to permit continued product improvement. Furthermore, since introducing the AT-AUTO, our customers have requested several features that we simply did not anticipate, but we are very happy that we were able to meet those requests through improvements in the firmware. If building a QRO, fully-automatic tuner were simple, others would have done so already.

Chapter 19

User Notes

19.1 User Notes - Continued

19.2 User Notes - Continued

19.3 User Notes - Continued