

TEN-TEC Model 670 Keyer was designed specifically for use with the TEN-TEC Century/21 transceiver. Low voltage positive transistor switching is incorporated to interface with the transceiver keying circuit, resulting in a reliable and economical means of keying the transmitter. Model 670 features self-completing dits and dahs, preset weighting for optimum articulation in the most used speed range, speed control with a range between 6 and 50 words per minute and matching enclosure. Power for the keyer is drawn from the Century/21 supply, and so no separate on-off switch is needed.

#### SPECIFICATIONS

Keyer Output Circuit: Positive low voltage transistor switch.

Speed Range: 6 to 50 WPM.

Time Base: Keyer starts with paddle actuation.

Character Generation: Self-completing dits and dahs.

Weighting: Dit length increased approximately 10% at 20 WPM.

Power Required: 10-14 VDC taken from Century/21 supply.

Paddle: Single type. Molded plastic, with adjustable contact spacing.

Semiconductors: 1 Integrated Circuit; 5 Transistors; 9 Diodes.

Size: HWD 2" x 4" x 6"

Weight: 1 lb, 8 oz.

#### INSTALLATION

The cable attached to Model 670 contains two phono plugs. Connect plug with red marker into one of the two AUXILIARY 12 VDC jacks on rear panel of the Century/21, and the remaining plug into the KEY jack.

#### OPERATION

Actuating paddle from right to left with the forefinger will produce a string of dahs as long as the paddle is depressed. Actuation in the opposite direction with the thumb produces a string of dits. Thumb screws on either side of the paddle are used to adjust contact spacings, and hence the amount of paddle travel, to your preference. This spacing should not be too great, especially when sending at the higher speeds, so that effortless and correct spacing between characters and letters is maintained.

**CAUTION:** This keyer will not key transmitters with cathode or grid-block keying. Application of high positive or negative voltages such as those encountered in these keying circuits will damage the switching transistor in the keyer. **OUR WARRANTY DOES NOT COVER DAMAGE INCURRED WHILE ATTEMPTING TO KEY TRANSMITTERS OTHER THAN THE TEN-TEC CENTURY/21.**

#### CIRCUIT DESCRIPTION

Q1, Q2 and Q3 constitute a relaxation oscillator whose frequency is determined by the RC combination of C1, R1 and R2. The oscillator is keyed to the oscillating state when either the dit or dah paddle contact is grounded. This connects the base of Q2 to ground through either D7 or D9. These diodes

---

---

---

Output from the relaxation oscillator is applied to the dual flip-flop, IC-1.

When the first pulse is applied, the relaxation oscillator is turned on by applying a low voltage from pin 11, through D4, to the base of Q2. With the application of the second pulse from the oscillator to the flip-flop, the state of pin 11 is again changed, and the high voltage from this pin is blocked by D4. This allows the oscillator to stop operation. The square wave produced at pin 10 of the flip-flop is applied to the base of keying transistor Q4, which in turn keys a dit to the transmitter.

The same procedure is followed for the dah, except that when this contact is closed, the second flip-flop in IC-1 is "set" or enabled by applying a pos-

---

flip-flop is twice the length of the dit, so that when the two flip-flop outputs are serially added and applied to Q4, the total length of time for the dah is the required three dit lengths.

C4 in conjunction with R8 provides a time constant that slightly lengthens the pulse applied to the base of Q4 and thus provides a small amount of weighting to the character length.

Approximately 13 VDC from the Century/21 supply is applied to zener diode D2 through dropping resistors R11 and R12, and is regulated by the diode to

---

#### INCREASING MAXIMUM SPEED

To increase the maximum speed limit from the factory setting of 50 WPM, replace R2 on the PC assembly with a resistor of lesser value. A 1.8K resistor will increase the maximum speed attainable to approximately 90 WPM. Values between 3.3K and 1.8K will provide maximum speeds between 50 and 90 WPM. The lowest speed of 6 WPM will only slightly be increased by changing R2. The increased speed range resulting from this modification may somewhat reduce the ease of setting the control to the desired speed. To compensate for this, you may want to increase the minimum speed as detailed in the next paragraph.

#### INCREASING MINIMUM SPEED

The minimum speed attainable can be increased from 6 WPM by bridging a resistor across the two active terminals of the SPEED control R1, or by replacing the control with one of smaller total resistance. For example, a 27K resistor shunted across the control, or a replacement control of 15K, will increase the minimum speed to approximately 9 WPM. Lower resistance will further increase minimum speed. This modification has no effect on the maximum speed limit since the control is completely out of the circuit when fully clockwise.

#### REMOVING WEIGHTING CIRCUIT

---

#### LEFT-HANDED CW OPERATORS

If you wish to switch the dit and dah paddles, simply exchange the two wires going between the paddle assembly and the PC board to the opposite board terminals.

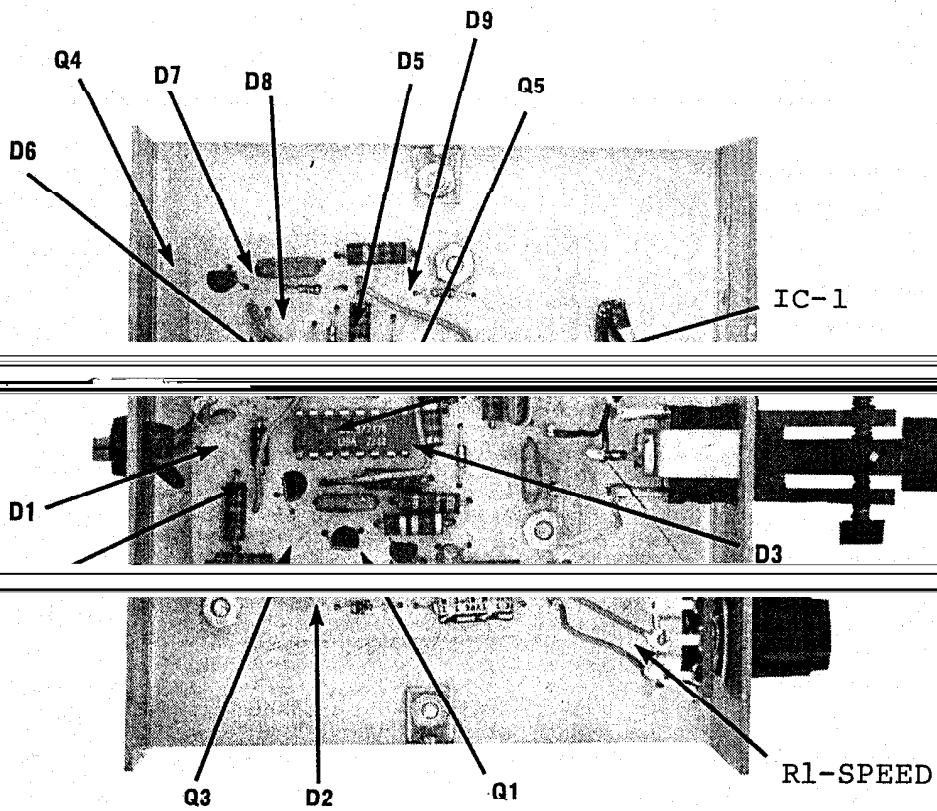
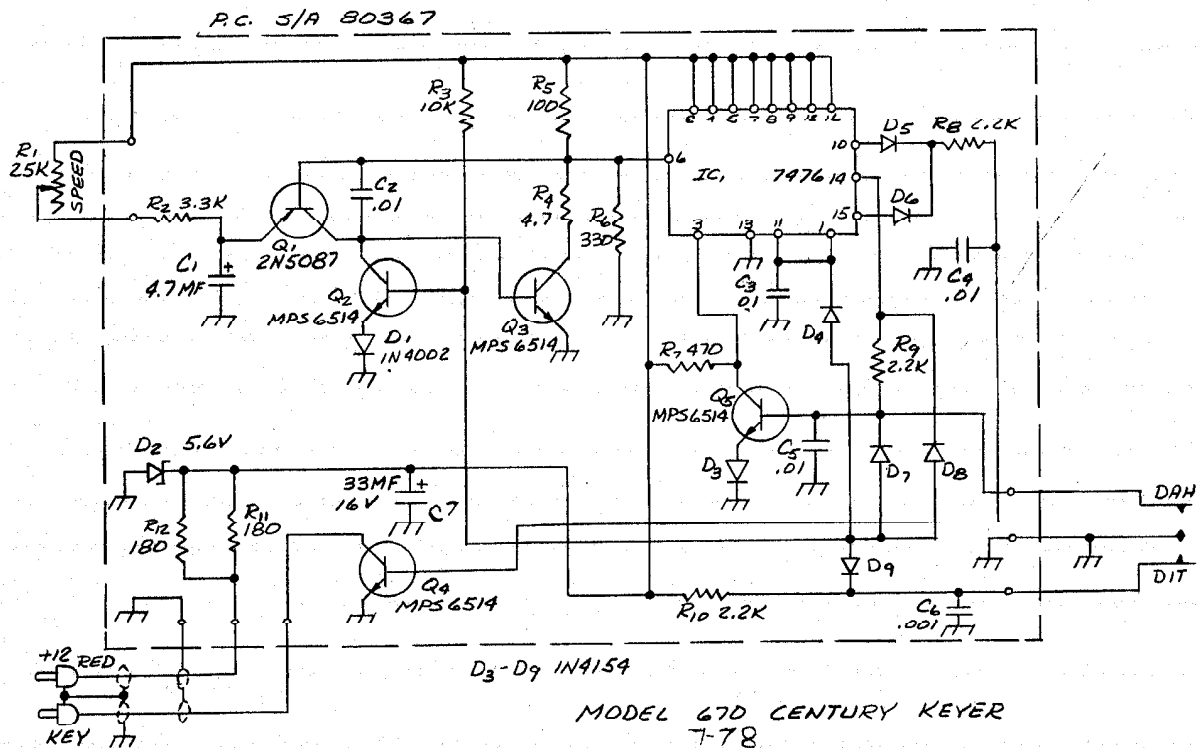

MODEL 670 CENTURY KEYER