



INSTRUCTION MANUAL

HF AUTOMATIC
ANTENNA TUNER
AH-2

Icom Inc.

FOREWORD

Thank you for choosing this Icom product.

The AH-2 HF AUTOMATIC ANTENNA TUNER incorporates an 8-bit microcomputer to digitally detect optimum matching conditions between an antenna and transceiver. Also equipped with a serial bus line, the AH-2 may be connected to an Icom transceiver equipped with a CI-V system such as the IC-735, IC-765, etc.

Please read this instruction manual prior to using your new tuner to obtain a thorough understanding of how to use and enjoy the AH-2 Antenna System.

CAUTIONS

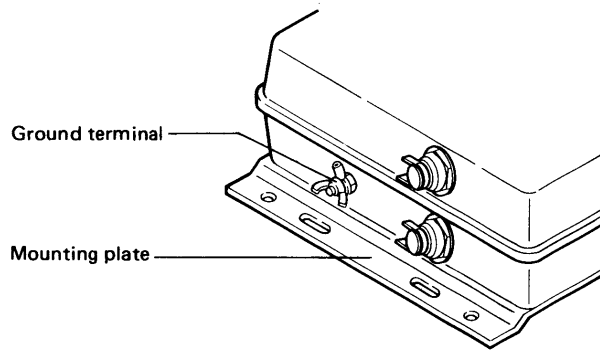

NEVER USE THIS TUNER WHEN IT IS UNGROUNDED. ALWAYS GROUND THE TUNER THROUGH THE GROUND TERMINAL BEFORE OPERATING. DO NOT use the mounting plates as ground.

NEVER TRANSMIT OR TUNE WITHOUT AN ANTENNA. Failure to use an antenna will damage the tuner.

HIGH VOLTAGE! NEVER TOUCH THE ANTENNA WHILE TRANSMITTING OR TUNING. Place the antenna in a position where you are sure it will not be touched.

DO NOT ATTEMPT USING MORE THAN 120W OF POWER. The internal relays may be damaged.

TABLE OF CONTENTS

SECTION 1	FEATURES	1
SECTION 2	SPECIFICATIONS	2
SECTION 3	GENERAL DESCRIPTION	3
SECTION 4	INSTALLATION	5
SECTION 5	OPERATION	10
SECTION 6	INSIDE VIEWS	12
SECTION 7	BLOCK DIAGRAM	13
SECTION 8	AH-2b (OPTION).....	14

SECTION 1 FEATURES

- **WIDE IMPEDANCE MATCHING RANGE**

The AH-2 provides reliable matching for frequencies from 3.5MHz to 30MHz using the AH-2b Antenna Element kit, permitting all band operation.

When using an antenna element with a length of 12 meters or more, operation over the 1.9MHz band is also possible.
- **AUTOMATIC, DIGITAL TUNING**

The tuner unit of the AH-2 permits automatic selection of the optimum matching conditions via its built-in 8-bit microcomputer and LC (coil/capacitor) circuit. Any of more than 260,000 different LC combinations are possible when tuning your antenna system.
- **ICOM BUS LINE CONTROL**

The controller unit of the AH-2 is connected to an Icom CI-V transceiver such as the IC-735 by Icom's unique serial bus line, allowing easy, rapid matching with one push of the TUNE switch.
- **8 CHANNEL MEMORY**

The tuner unit has a built-in memory capable of storing tuning information for 8 different frequencies, allowing tune up to be completed in 1 second or less on these frequencies.
- **THROUGH/TUNE SWITCH**

Either the THROUGH or TUNE function may be selected quickly from the front panel.
- **REDUCED INTERFERENCE TO OTHER STATIONS**

Since conventional tuners operate with full output power for a relatively long time during tune up, they may cause disruption of other communication already in progress. The AH-2 minimizes interference to other stations by using just 0.3 watts radiated power for a short tuning period.
- **WATERPROOF, DUSTPROOF DESIGN**

The tuner unit, installed directly under the antenna, is constructed in a tightly sealed plastic enclosure with a watertight rubber gasket.

SECTION 2 SPECIFICATIONS

Frequency range	: 3.5 ~ 30MHz (when used with AH-2b) 1.8 ~ 30MHz (when antenna length is 12 meters or longer)
Maximum input power	: 120W
Input impedance	: 50 ohms
Tuning power	: 10W (5 ~ 15W)
Tuning time	: 2 ~ 4 seconds average (20 seconds maximum)
Rated voltage	: 13.8V DC \pm 15% (negative around)
Rated current	: 2A or less
Usable temperature range	: $-10^{\circ}\text{C} \sim +60^{\circ}\text{C}$ ($+14^{\circ}\text{F} \sim +140^{\circ}\text{F}$)
VSWR*	: 1.5 : 1 or less (when used with AH-2b)
Weight	: Controller unit 0.7kg Tuner unit 2.4kg
Dimensions	: Controller unit 53mm(W) x 63mm(H) x 205(210)mm(D) Tuner unit 230mm(W) x 85mm(H) x 380(395)mm(D) Bracketed values include projections.

*When using an antenna other than the AH-2b, those frequencies which are 1/2 wavelength or multiples are excluded.

All stated specifications are subject to change without notice or obligation.

SECTION 3 GENERAL DESCRIPTION

The complete AH-2 system consists of the AH-2a, which includes the tuner unit and the controller unit, and the AH-2b automobile antenna element. Although it is recommended that you use the AH-2a with an Icom CI-V transceiver, the tuner may also be used with Icom HF transceivers.* When the connected transceiver does not use the CI-V system, mode changing must be done manually.

* Some transceivers cannot be connected to the AH-2.

■ FUNCTION OUTLINE (AH-2a)

The AH-2a includes the controller unit and the tuner unit. The controller unit, equipped with the microcomputer (CPU), connects the transceiver to the tuner unit. While tuning, the controller forces the transceiver to the FM mode and controls the ALC circuit so the transceiver delivers a constant 10 watt output.

The controller is also equipped with light-emitting diodes (LEDs) as function indicators and switches for selecting the different functions.

The tuner unit is an automatic tuner which monitors the antenna element impedance, the SWR, etc. during tuning and adjusts the electronic components within the tuner for a matched condition between the antenna and the transceiver.

3-1 CONTROLLER UNIT

The functions and connections mentioned below are mainly in reference to the IC-735 transceiver. Also, "tuning" refers to the operation of measuring the system impedance and adjusting the L (coil) and C (capacitor) components.

■ FRONT PANEL

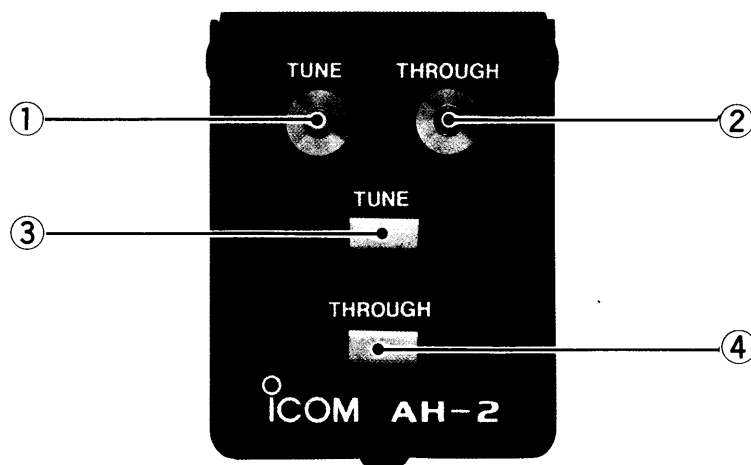

① TUNE LCD (2-color LED)

This LED indicates the current status of the system as follows:

- (1) The green LED lights when the tuner unit completes the tuning operation and the system is correctly matched.
- (2) The red LED lights while the tuning operation is in progress.
- (3) The red (TUNE) and yellow (THROUGH) LEDs light when the tuner unit is unable to correctly match the system.

② THROUGH LED

This LED lights when the tuner unit is in the THROUGH condition. That is, the output from the transceiver is fed directly to the antenna.

③ TUNE SWITCH

Push this switch to start the automatic tuning operation.

④ THROUGH SWITCH

Push this switch to select the THROUGH condition.

■ TOP PANEL

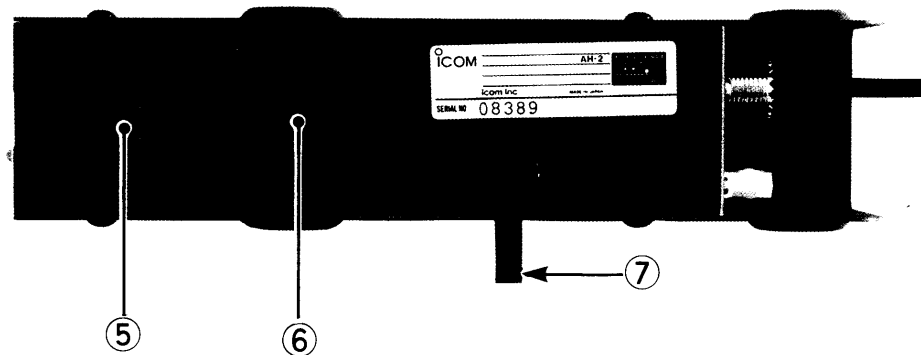

⑤ POWER JACK

Connect an accessory power cable to this jack.

⑥ REMOTE JACK

Example:
 SSB (operating mode)
 ↓
 FM (tuning mode)
 ↓
 SSB (operating mode)

This jack is an input/output port for transmitting and receiving control signals with a CI-V transceiver. This control line transfers the signal which automatically switches the transceiver to the FM mode and returns the transceiver to the operating mode on completion of tuning.

⑦ ACC CABLE

This cable connects to the ACC connector on the transceiver. Refer to page 9 for details.

■ REAR PANEL

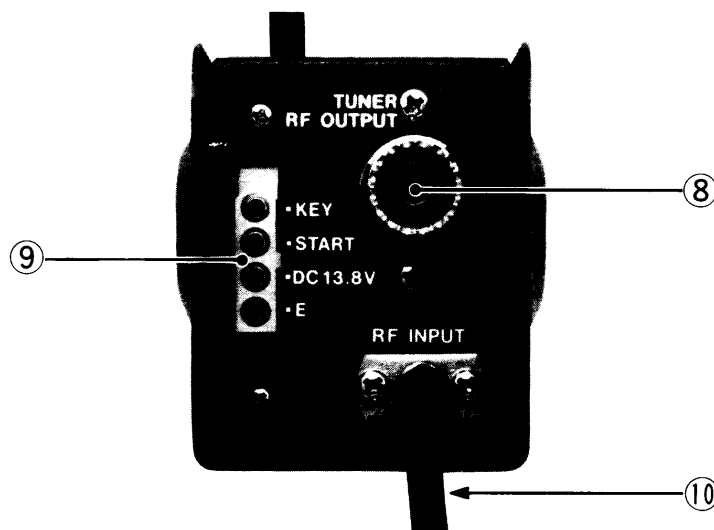

⑧ RF OUTPUT CONNECTOR

Connect the coaxial cable from the tuner unit here. Refer to page 9 for details.

⑨ CONTROL CONNECTOR

Connect the 4-conductor control cable from the tuner unit here. Refer to page 9 for details.

⑩ RF INPUT CABLE

This coaxial cable connects to the transceiver antenna connector.

SECTION 4 INSTALLATION

4 - 1 UNPACKING

Remove your tuner from the packing carton and examine it for signs of shipping damage. Notify the delivering carrier or dealer immediately, stating full details, should any damage be apparent. We recommend you keep the shipping carton for storing, moving or reshipping the tuner if necessary. Accessory hardware, cables, etc. are packed with the tuner. Make sure you have removed all equipment and parts before discarding the packing material.

1. U-bolt	2
2. U-bolt plate	2
3. Flat washer (large) (M6)	8
4. Flat washer (small) (M6)	4
5. S-washer (M6)	8
6. Nut (M6)	8
7. Hex bolts (M6 x 50)	4
8. Self-tapping screw (6 x 30 AO)	4
9. Strain relief	2
10. PL-259 connector	2
11. Waterproof cap	1
12. Power cable	1
13. Remote cable	1
14. Control cable (4-conductor, 5 meters)	1
15. Coaxial cable (5 meters)	1

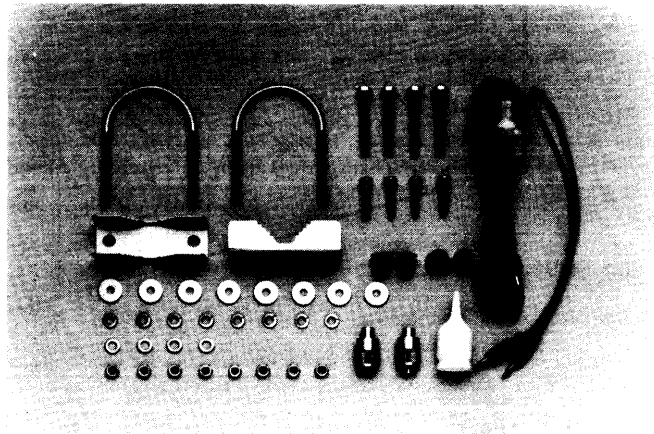

4 - 2 CONTROLLER UNIT

● MOUNTING THE CONTROLLER

(1) Loosen the 2 top cover screws on the side of the transceiver and mount the controller as shown in the figure.

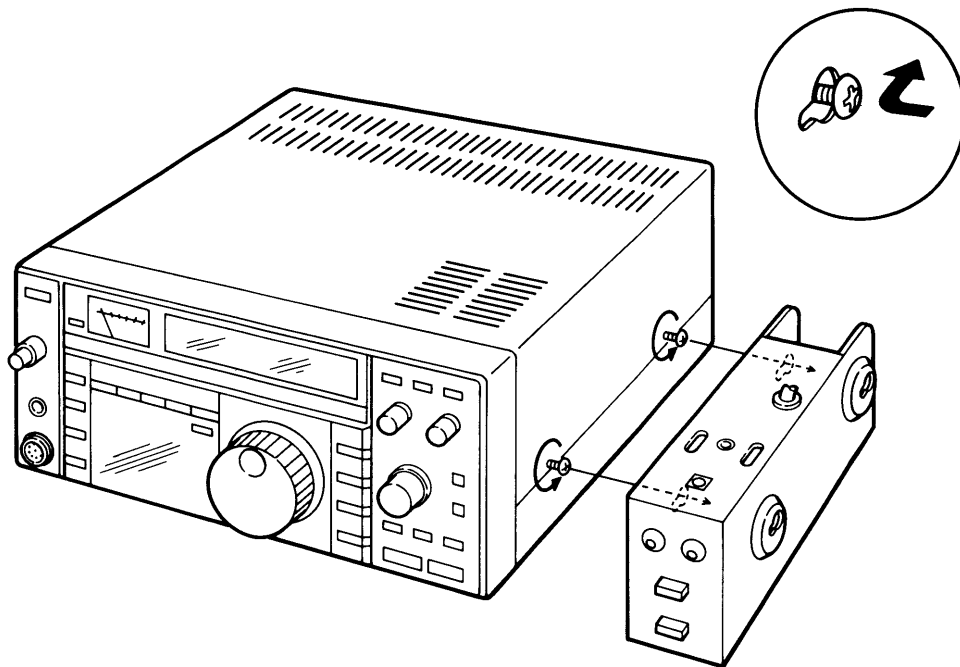

- (2) Insert a screwdriver through the holes in the side of the controller and tighten the 2 screws.

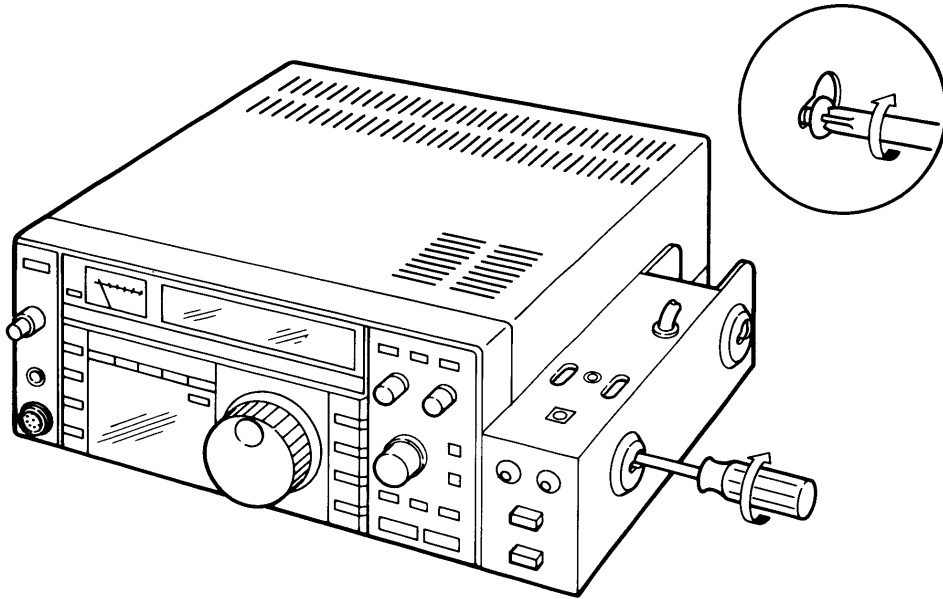

4-3 TUNER UNIT

●CONTROL CABLE AND COAXIAL CABLE CONNECTION

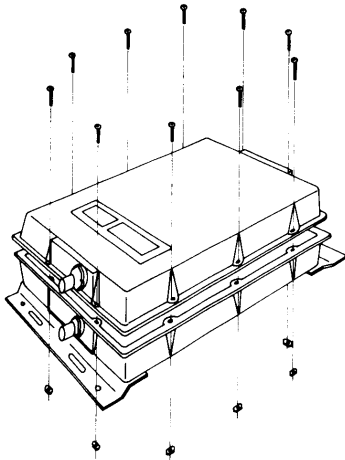

- (1) Loosen the 10 cover screws and remove the upper cover as shown.
- (2) Loosen the strain relief screw on the lower cover, insert the control cable through the strain relief and connect it to J8 ~ J11.
- (3) Loosen the strain relief screw on the upper cover, insert the coaxial cable through the strain relief and then solder a PL-259 connector to the end of the cable which is inside the tuner unit.
- (4) Connect the control cable and coaxial cable, and mount the upper cover.

NOTE: The strain reliefs are designed to allow three different cable diameters to be used. Use the best-fitting inner diameter for the cable you are using.

●SOLDERING PL-259 CONNECTORS

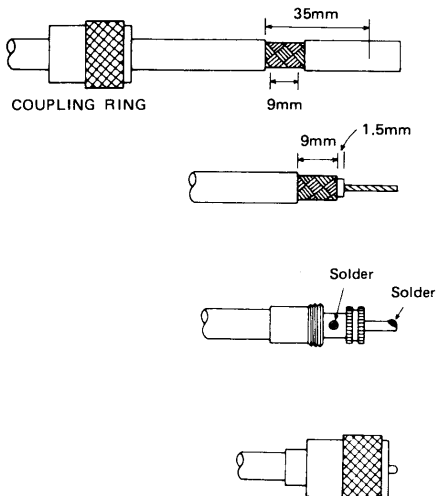

- (1) Slide the coupling ring over the coaxial cable.
- (2) Strip the cable as in the figure, and tin about one-half inch of the shield conductor.
- (3) Remove the outer plastic casing and strip the center conductor insulation as in the figure. Tin the center conductor.
- (4) Slide the connector body onto the cable end and solder.
- (5) Screw the coupling ring onto the connector body.

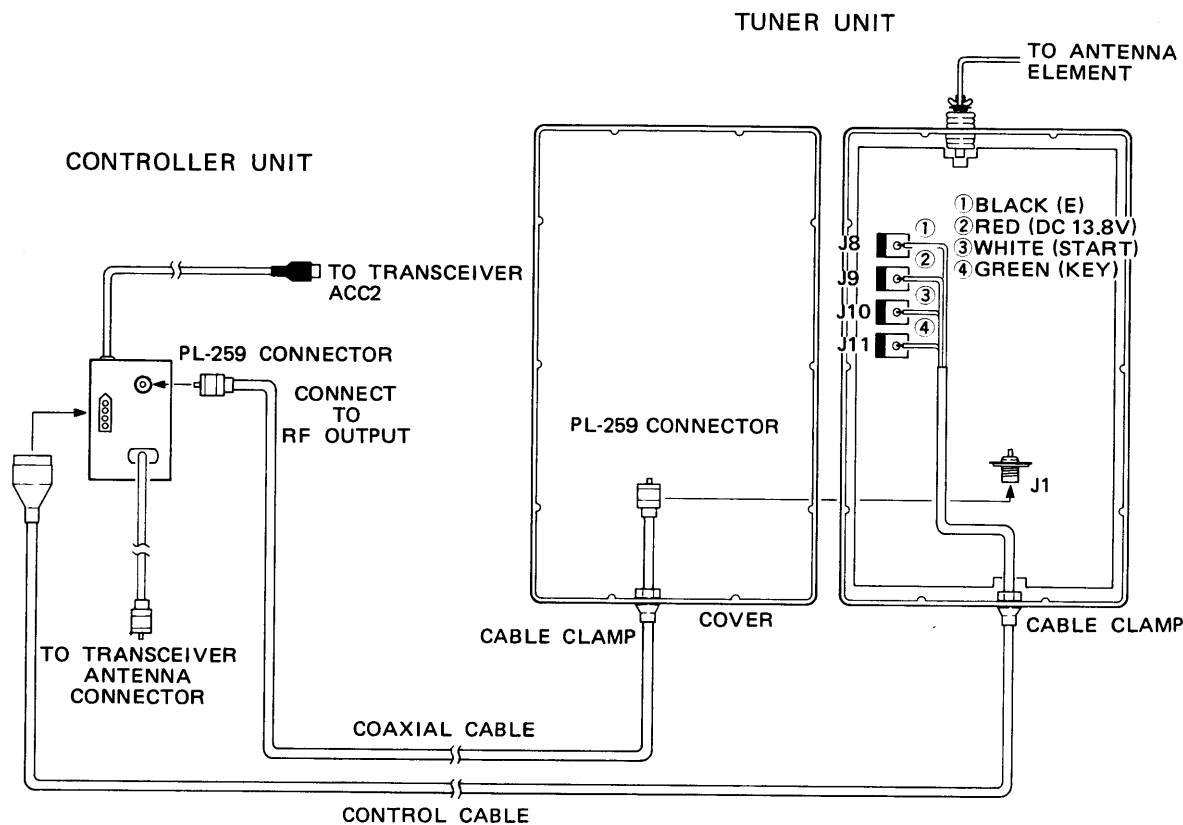

•TUNER UNIT INSTALLATION

- (1) Select a mounting location which is close to the base of the antenna element. Also, the feeder cable between the tuner unit and the antenna element should be longer than 50 centimeters. Total length of the antenna element plus feeder cable should be 3 meters or longer.
- (2) Hardware is provided for three types of installation. Use either:
 - a) hex bolts,
 - b) self-tapping screws, or
 - c) U-bolts.
- (3) Install the tuner unit horizontally or with the input cable from the transceiver entering at the bottom.
- (4) Mount the tuner as shown in the figure. Use the attached angle brackets to mark the location of the four holes required for the screws. However, note that screw hole diameters required are different for the bolts and the self-tapping screws. The diameters are as follows:
 - a) bolt holes : 6.5 ~ 7mm
 - b) screw holes: 5mm
- (5) Connect a wire from a good electrical ground to the ground terminal provided on the end of the tuner unit. When attaching a ground to the chassis of a car, remove all paint from the connection point to provide the best electrical contact. Also, use a ground cable or strap with as large a diameter as is available. An inadequate ground may produce a high VSWR or prevent the tuner from operating efficiently.
- (6) Provide sufficient insulation for the feeder cable. Use extra care when passing the cable through chassis holes.

● Installation with nuts

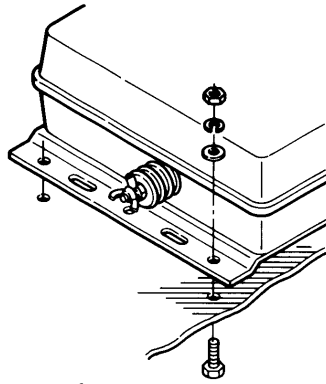

● Installation with self-tapping screws

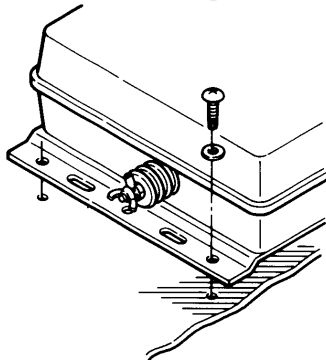

● Installation with U-bolts*

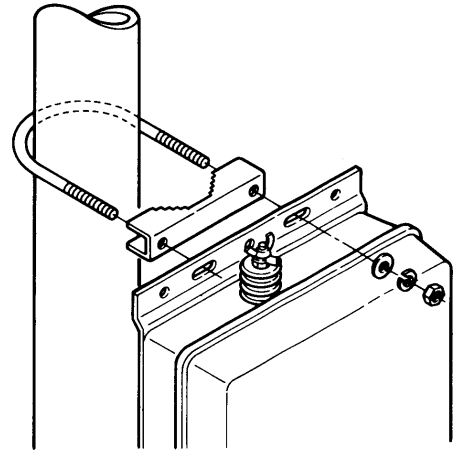

*Fixed location installation.

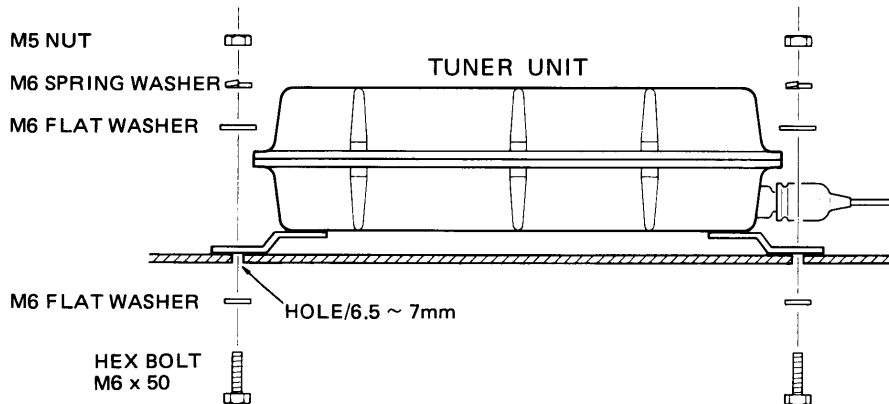

■ ACC CABLE

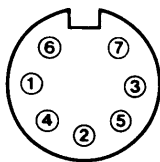

FRONT VIEW

Pin No.	Name	Description
1	NC	Not connected.
2	GND	Ground.
3	SEND	Grounded during tuning.
4	NC	Not connected.
5	ALC	Automatic level control.
6	NC	Not connected.
7	13.8V	13.8V input switched by the main power switch on the transceiver.

4-4 CONNECTION DIAGRAMS

(1) Connect the AH-2 to the transceiver and antenna as shown in the figures.

■ CI-V TRANSCEIVER

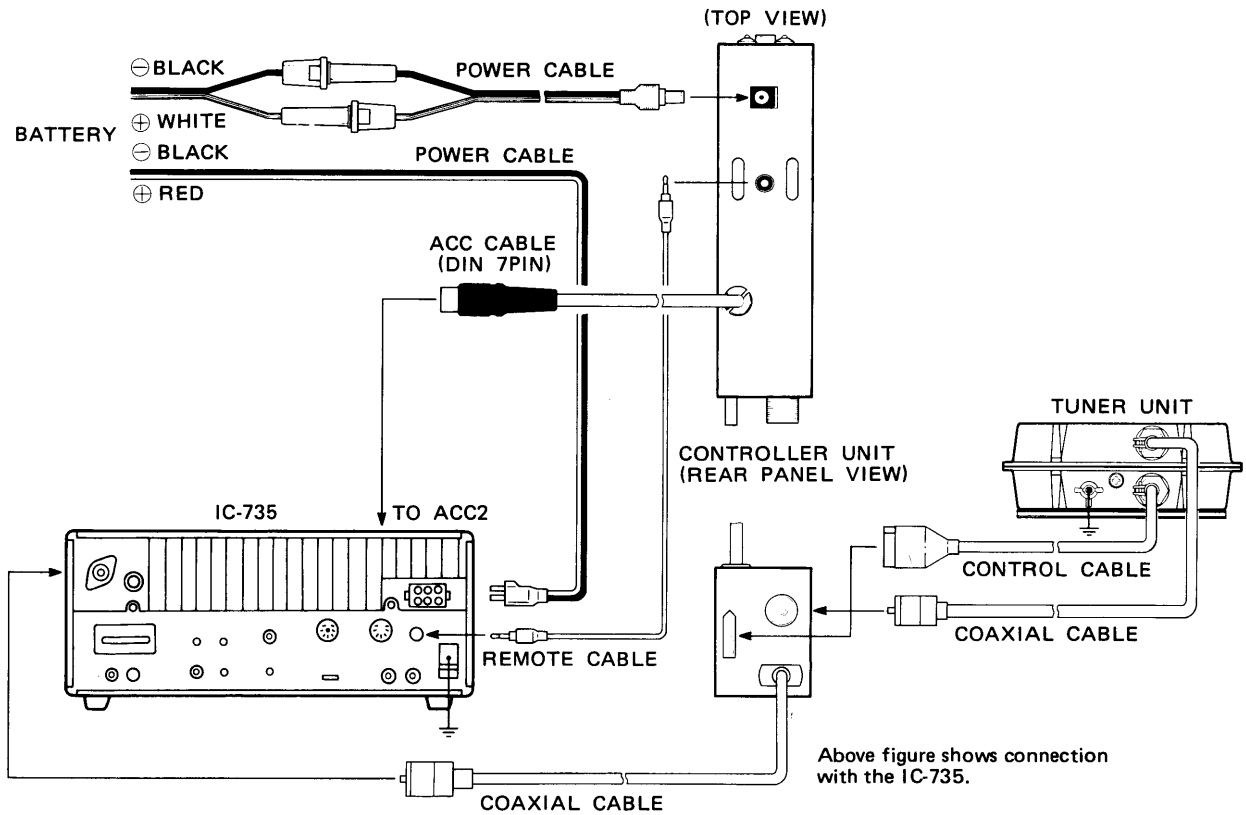

■ ANOTHER ICOM TRANSCEIVERS

NOTE: When using equipment which has a 24-pin ACC socket, it is necessary to adjust the tuning power. See page 11 for details.

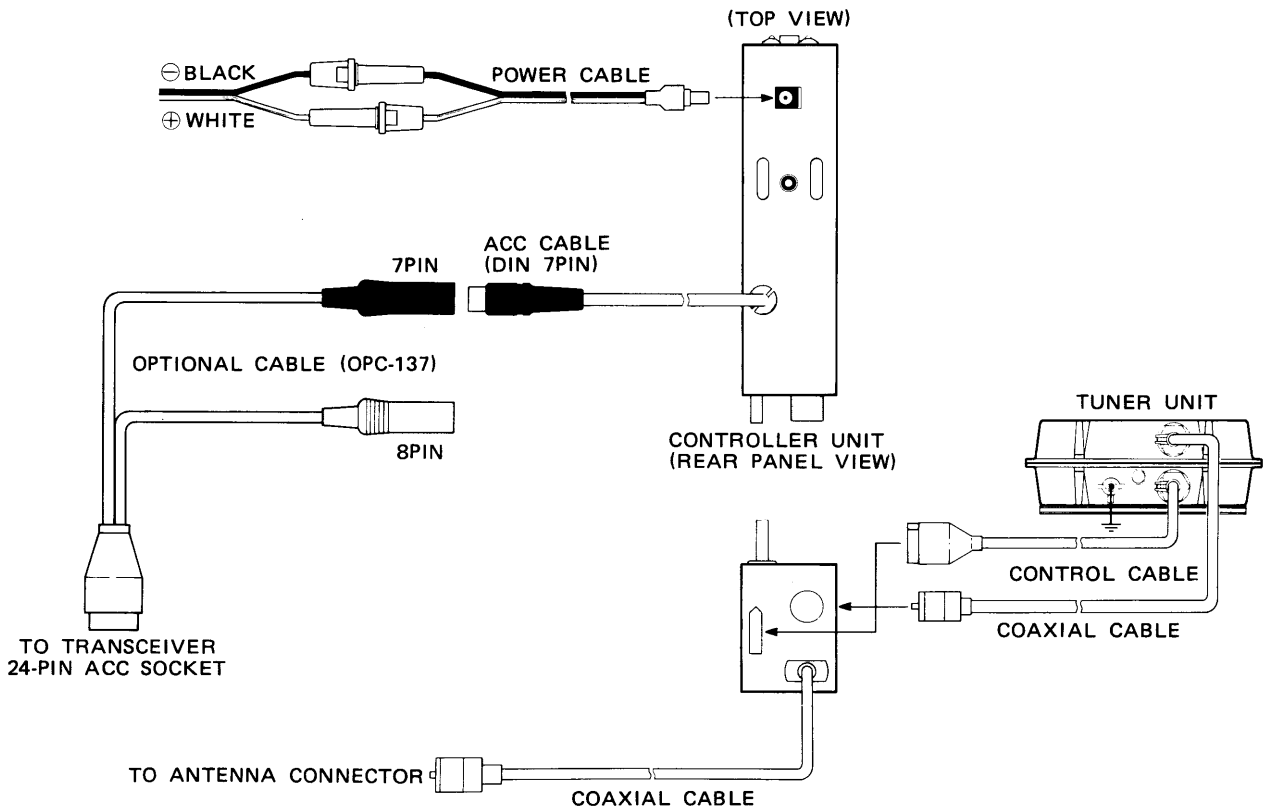

SECTION 5 OPERATION

■ CI-V TRANSCEIVER

- A CI-V transceiver and the controller unit of the AH-2 are connected by a serial bus line. Incorporated in the controller is a microcomputer which controls the tuning operation instructions. It also carries out a series of operations and checks, such as storing the current operating mode while tuning is in progress, setting the transceiver mode, setting the transmit power to 10 watts, stopping the tuning transmission and returning the transceiver to its original operating mode.

- (1) Push and release the TUNE SWITCH on the controller unit to start the automatic tuning function.

■ ANOTHER ICOM TRANSCEIVER

- When using a non-CI-V transceiver, select a mode with a constant carrier output (FM, RTTY, CW).

- Push and release the TUNE SWITCH on the controller unit to start the automatic tuning function.

- Return to your operating mode after tune up is completed.

5 - 1 TUNING

- (1) The average tuning time is 2 to 4 seconds. Maximum tuning time is 20 seconds. While tuning, the red LED on the front panel of the controller (TUNE LED) lights.

- (2) When tuning is finished, the green LED (TUNE LED) lights if the matching is successful, or the red LED (TUNE LED) and yellow LED (THROUGH LED) light if the matching is not correct.

- Reasons for unsuccessful matching are as follows:

The antenna element length is too short for the operating frequency in use.

NOTE: Standard antenna element lengths are:

- a) 1.8MHz: 12 meters or more
- b) 3.5MHz: 3 meters or more
- c) 7MHz and higher: 2 meters or more

The sum of the antenna element length plus the feedline from the tuner to the antenna base should be greater than the above value.

The longer the antenna element, the better will be the antenna efficiency. Also, if installed in an automobile, efficiency is improved when an additional length of wire is clipped onto the antenna element.

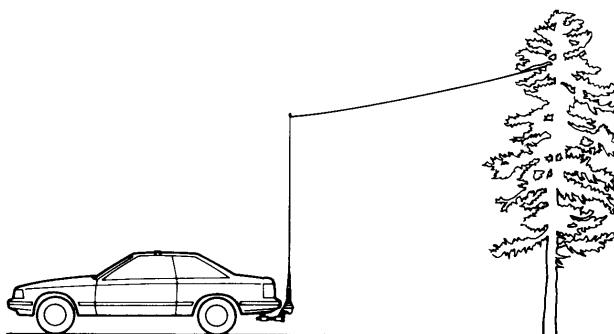

- Remember, when tuning frequencies outside the standard bands, the tuner does not function since there is no transmit output power from the transceiver.
- After pushing the TUNE SWITCH on the AH-2 controller, do not attempt to change the operating frequency of the transceiver or transmit until the tuning operation is finished.

- (3) To interrupt the tuning operation, push the THROUGH SWITCH. The tuning stops and the yellow LED (THROUGH LED) lights.
- (4) As long as the power is not turned off, the memory stores data for 8 different frequencies once tuning has been completed. When one of these frequencies is selected again, tuning will take only about 1 second. If the original tuning time was less than 2.5 seconds, however, the data for this frequency is not stored in memory.

After making a significant frequency shift within the same band, always push the TUNE SWITCH again to ensure the best performance from the AH-2 system.

5 - 2 OPERATING

NOTE: PREVENT ELECTRICAL SHOCKS. Do not install or operate your AH-2 system at a location where the antenna element may be touched. High voltage is present.

- (1) Never transmit into the tuner with either the antenna element disconnected from the base or with no ground. Parts damage could result.
- (2) When operating from a moving vehicle, take care the antenna element does not interfere with other vehicles on the road. When operating while stationary, ensure that nobody touches the antenna element while transmitting.

CAUTION: DO NOT TOUCH THE ANTENNA ELEMENT WHILE TRANSMITTING. HIGH VOLTAGE IS PRESENT.

5 - 3 TUNING POWER.

- (1) Remove the 6 cover screws (black) from the controller.
- (2) Connect the RF input cable from the controller to the ANT terminal of the HF equipment, and an OPC-137 optional cable between the ACC cable from the controller and the ACC connector (24 pin) on the rear panel of the HF equipment. Refer to the connection diagram. Do not connect the power cable from the controller.
- (3) Connect a power meter to the RF output connector on the controller.
- (4) Adjust the transceiver for the following conditions:
 - a) FREQUENCY : 7 ~ 14MHz
 - b) MODE : RTTY, FM or CW (TRANSMIT)
 - c) RF POWER : Maximum

Using R3 in the controller unit, adjust for a power meter reading of 10 watts.

SECTION 6 INSIDE VIEWS

■ CONTROLLER UNIT

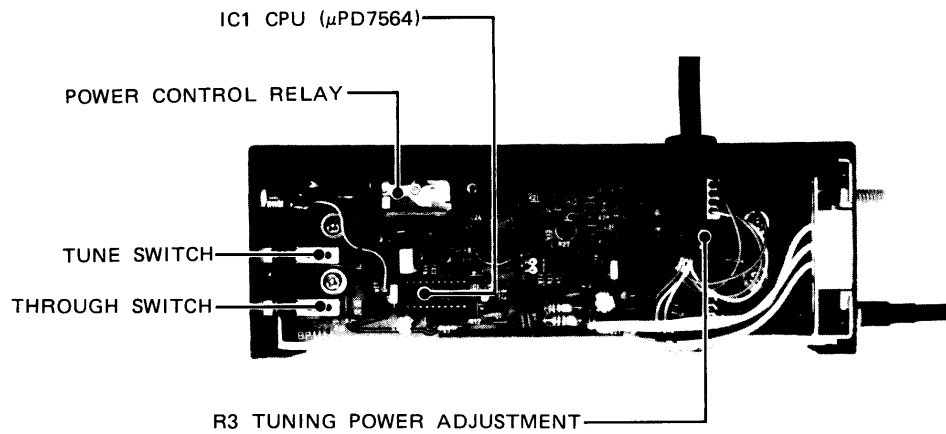

■ TUNER UNIT

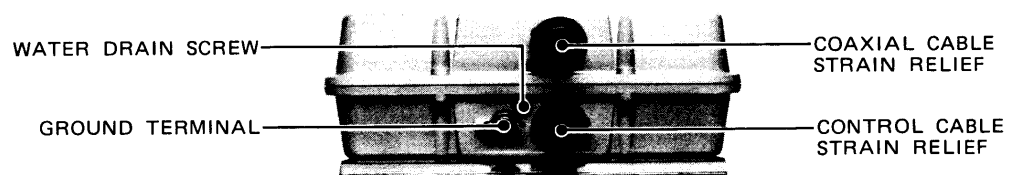
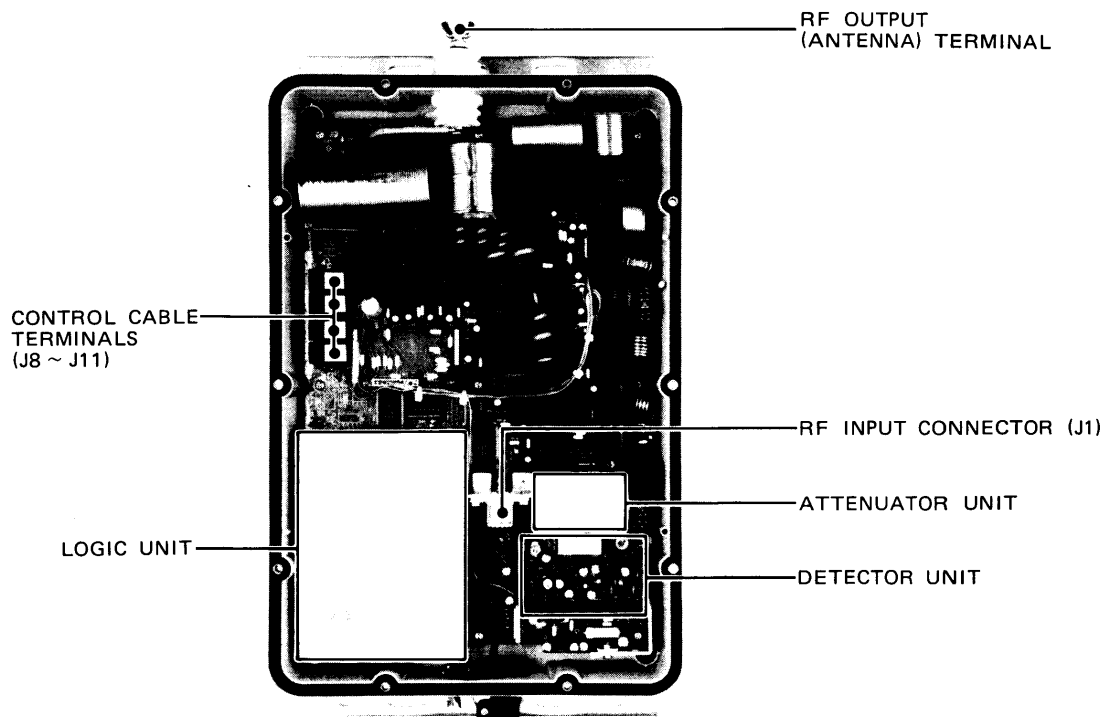

SECTION 7 BLOCK DIAGRAM

■ CONTROLLER UNIT

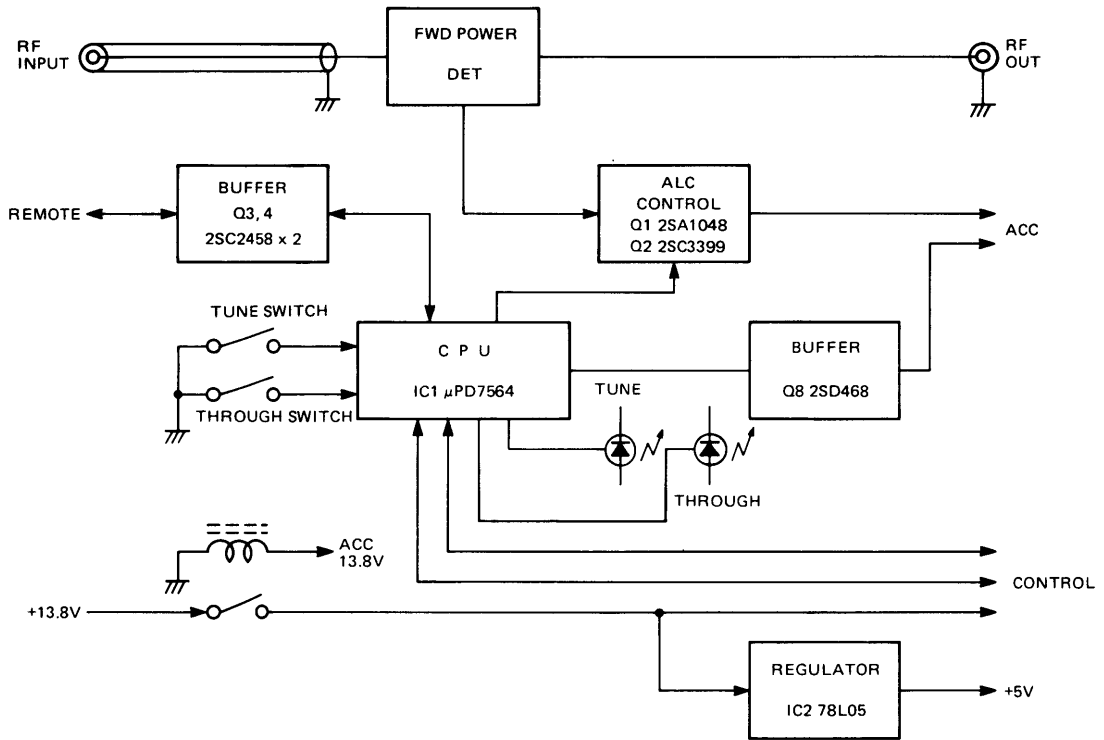

■ TUNER UNIT

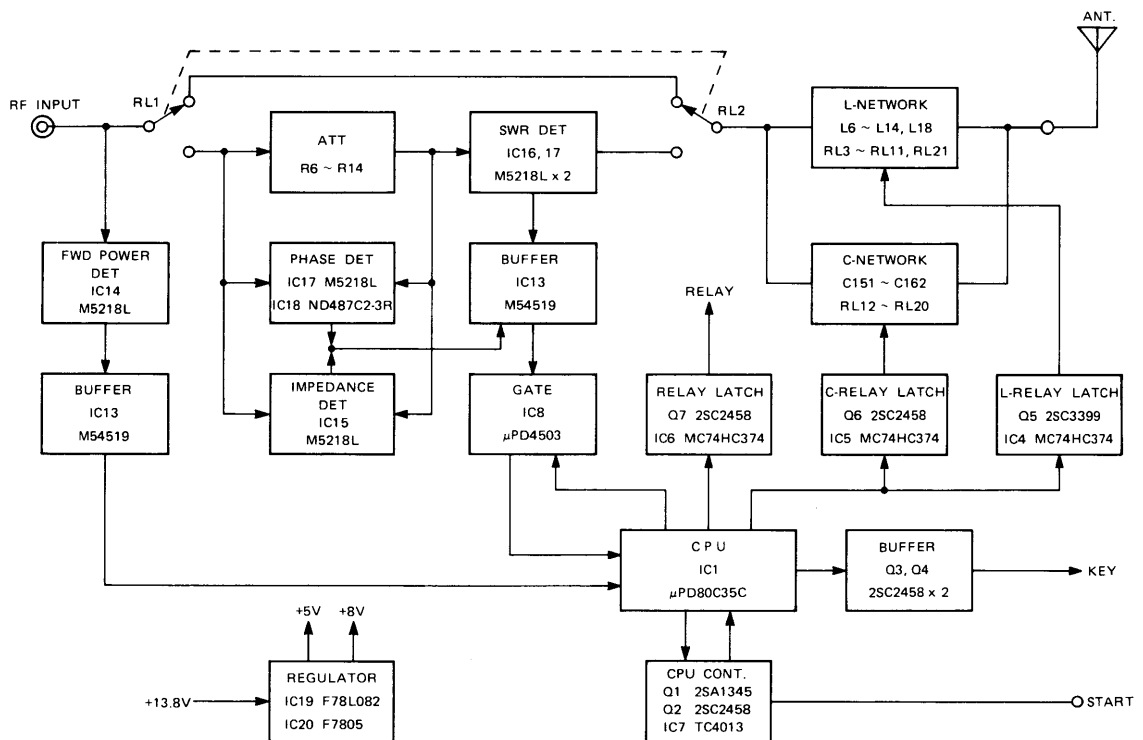

SECTION 8 AH-2b (OPTION)

- The AH-2b consists of an antenna element, antenna base, shaft (A), and tow hook and L angle brackets.
- The description below explains how to mount the AH-2b to an automobile tow hook.

MOUNTING METHOD

■ ATTACHMENT TO A VERTICAL HOOK

- (1) Attach the tow hook bracket to the automobile tow hook using a hex bolt, S-washer, flat washer and nut.
- (2) Insert shaft (A) into the tow hook bracket and attach with a hex bolt, S-washer and nut. Tighten the 3 other hex bolts into the tow hook bracket.
- (3) Attach the antenna base to shaft (A) with hex bolts, S-washer and nut. Tighten all bolts.

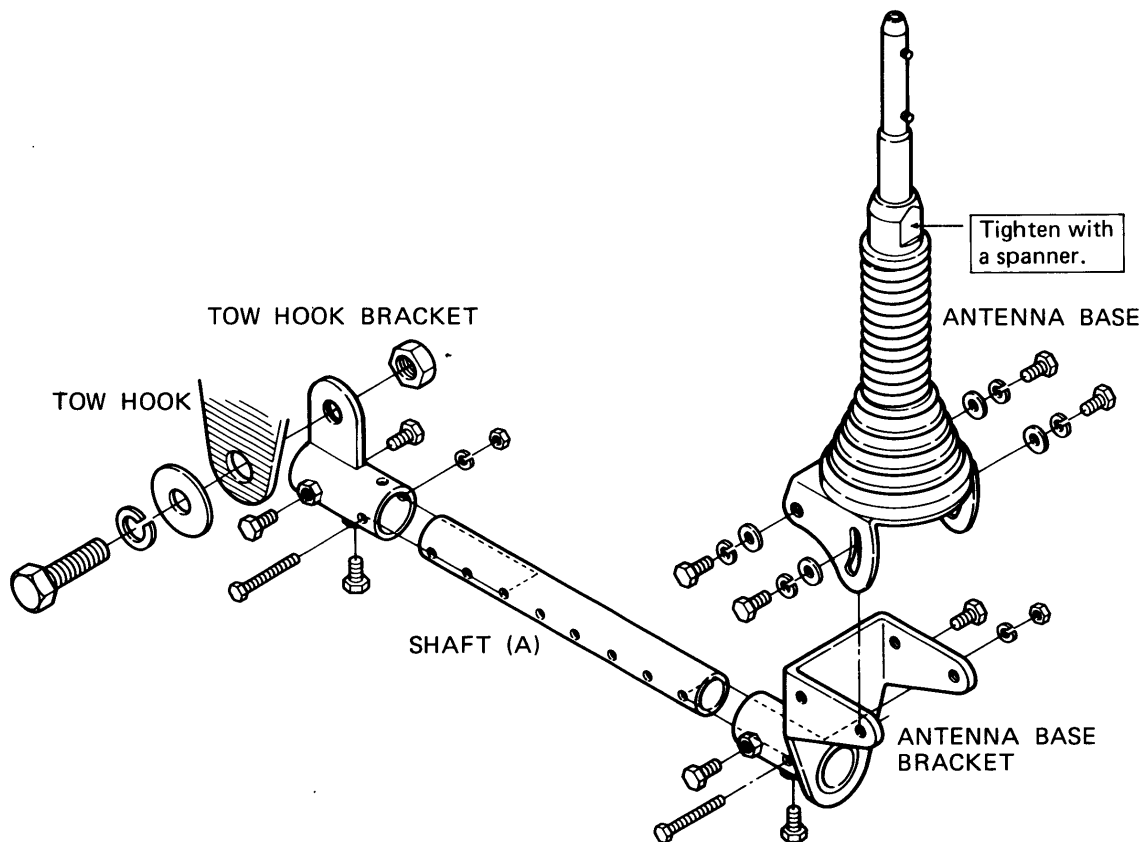

■ ATTACHMENT TO A HORIZONTAL HOOK

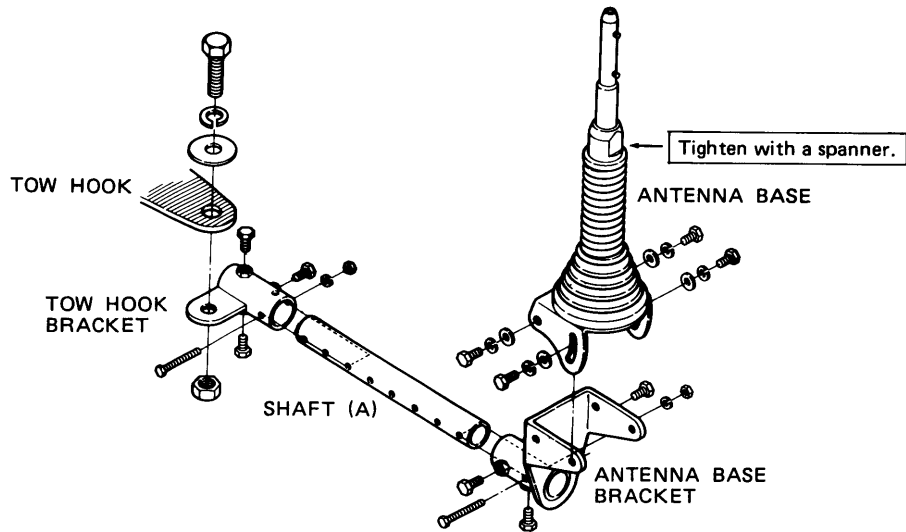

■ ATTACHMENT TO AN ANGLED HOOK

- (1) Attach the L angle bracket to the automobile's tow hook with a hex bolt, flat washer, S-washer and nut. Tighten securely.
- (2) Attach the tow hook bracket to the L angle bracket with a hex bolt, S-washer and nut. Tighten.
- (3) Follow steps (2) and (3) under ATTACHMENT TO A VERTICAL HOOK.

NOTE: Use a spanner and box wrench when tightening the nuts and bolts to prevent shifting of the antenna. Periodically check that the hardware is still tight.

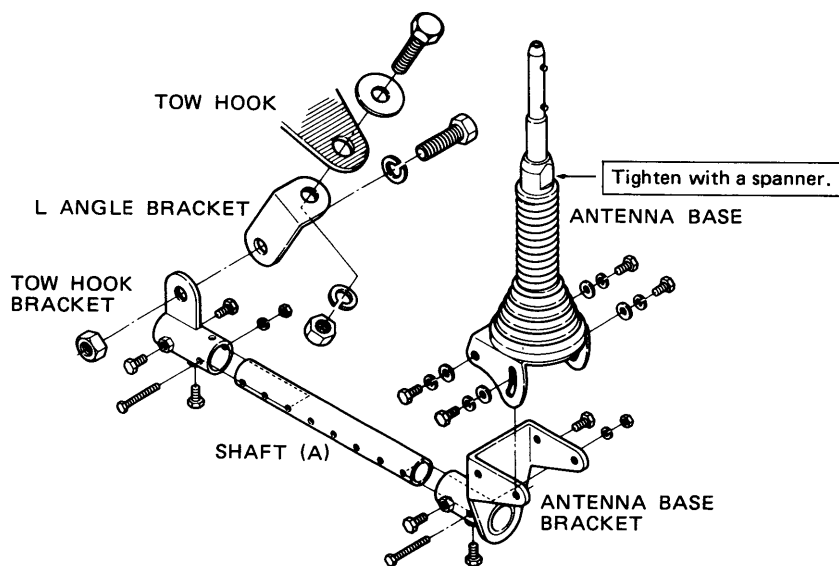

■ ANTENNA FEEDER CONNECTION
(TUNER UNIT to ANTENNA BASE)

- (1) Run the cable between the tuner unit and the antenna base using the waterproof cap and cable lock as shown in the diagram. The cable is 90 centimeters long and may be cut if necessary, but its length should be 50 centimeters or longer.

Avoid running the cable against or near the muffler or sharp metal parts outside the trunk.

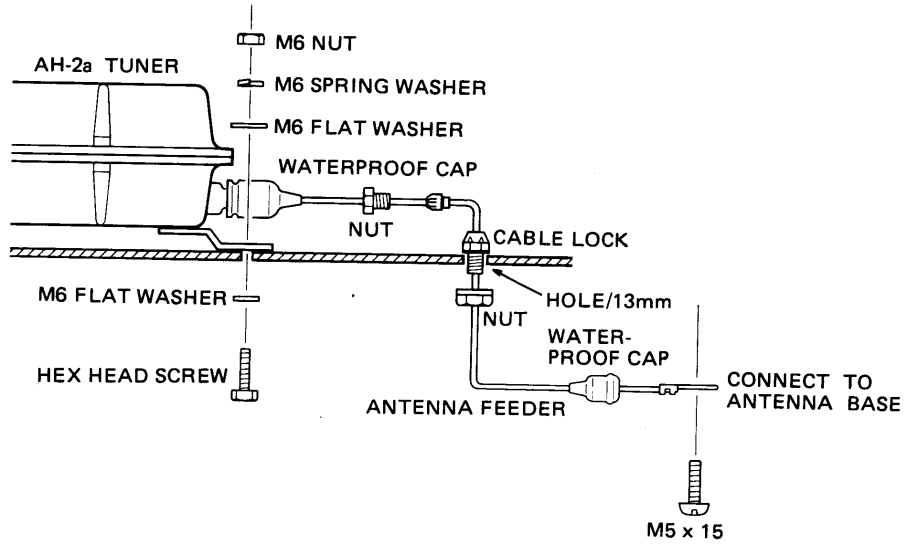

- (2) Connect the end of the cable to the antenna base as shown in the diagram.

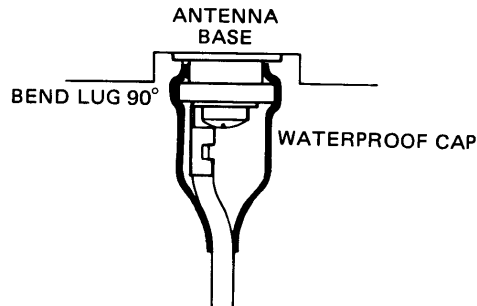

- (3) Prevent the cable from hanging loosely under the chassis by pulling excess slack into the trunk and tightening the cable lock.

Remember, the VSWR may be affected adversely if this feeder cable changes position or rubs against other objects.

■ MOUNTING THE ANTENNA ELEMENT

NOTE: The antenna element holder is loosely screwed into the antenna base spring at the factory. Be certain to tighten this joint with a spanner during assembly.

- (1) Insert the antenna element into the hole at the top of the antenna base. The element should enter the base as deep as 13 to 14 centimeters. Loosen the set screws further, if necessary, for proper element insertion.
- (2) Loosen the 4 hex bolts on bracket B and orient the element in a vertical position. Tighten the hex bolts.

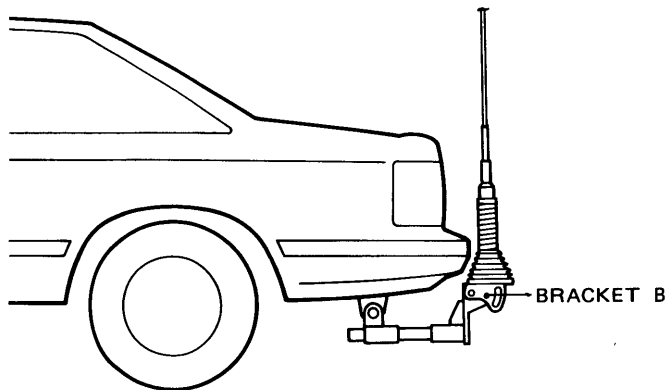
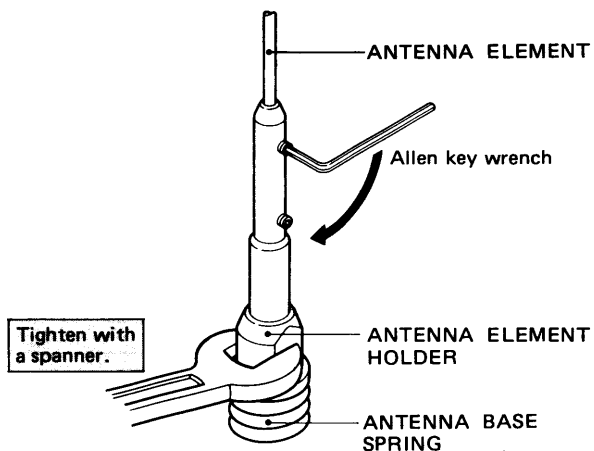

■ AUTOMOBILE ROOF ANTENNA ELEMENT CATCH

The purpose of the antenna element catch is to hold the antenna tip to allow easy parking, in a garage for example, or passage under overhead obstructions with little clearance.

- (1) Attach the antenna element catch to the automobile roof rain-gutter as shown in the diagram. Use the accessory allen key wrench to mount the catch.

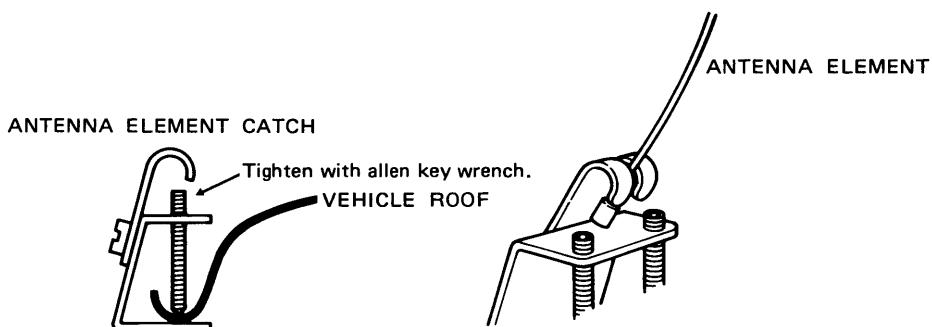

NOTE: PREVENT ELECTRICAL SHOCKS. Do not install or operate your AH-2 system at a location where the antenna element may be touched. High voltage is present.

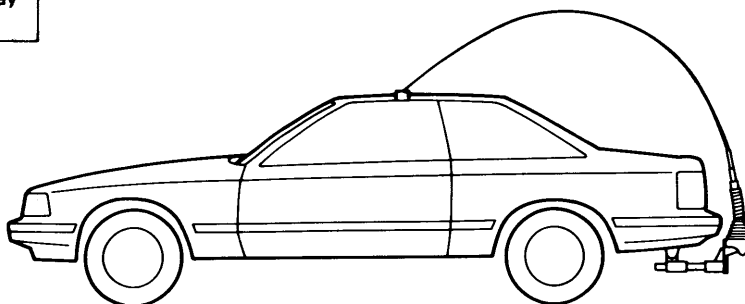

Count on us!